

Alcoa  
Fastening  
Systems



## *INSTRUCTION MANUAL*

# 244/244OS

*PNEUDRAULIC INSTALLATION TOOL*

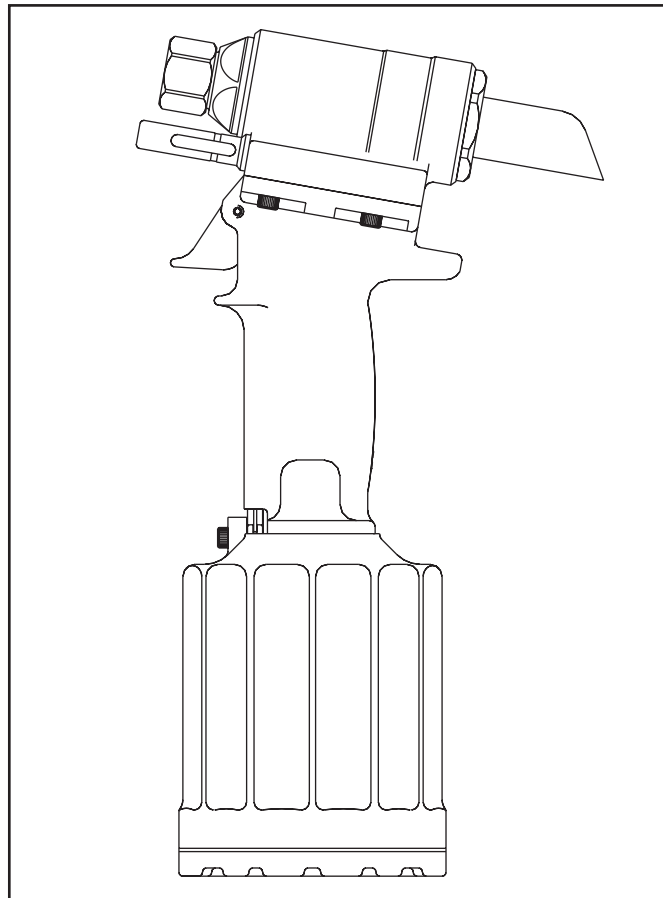

Makers of Huck®, Marson®, Recoil®  
Brand Fasteners, Tools & Accessories

Form HK 989  
03-01-2004



# EU Declaration of Conformity

**Manufacturer:**

Huck International, Inc., Installation Systems Division, 1 Corporate Drive, Kingston, NY, 12401, USA

**Description of Machinery:**

Model number 244 fastener installation tool

**Relevant provisions complied with:**

Council Directive related to Machinery, (89/392/EEC), (91/368/EEC), (93/44/EEC), (93/68/EEC)

**European Representative:**

Rob Pattenden, Huck International, Ltd. Unit C Stafford Park 7, Telford Shropshire TF3 3BQ, England, United Kingdom

**Authorized Signature/date:**

I, the undersigned, do hereby declare that the equipment specified above conforms to the above Directive(s) and Standard(s).

Signature: \_\_\_\_\_



Full Name: Henk Rosier

Position: Engineering Manager,  
Installation Systems Division

Place: Kingston, New York, USA

Date: August, 1998

### Huck Model 244/244OS Sound Power Level

The sound level of the 244/244OS tool cycling without fastener is

Sound Exposure Level (SEL) = 74.3 dB (A)  
Peak Value = 94.2 dB (C)

The noise of the fastener being installed in structure is considered process noise, not tool noise. Sound measurements of simulated process noise are available upon written request from Huck International in Kingston, NY, USA.

### Huck Model 244/244OS Vibration Level

For an eight hour work day, installing 3000 typical Huck fasteners will result in an equivalent weighted RMS vibration level (Aeq) of 2.04m/s<sup>2</sup>.

To calculate the equivalent vibration level for other quantities of fasteners in an eight hour period, use the formula:

Equivalent Vibration Level, Aeq (m/s<sup>2</sup>) = (n/480) x 2.04  
where n = number of fasteners in eight hours, and 2.04 (m/s<sup>2</sup>) = Aeq for 60 seconds.

Test data to support the above information is on file at Huck International, Inc., Kingston, NY, USA. Vibration measurements are frequency weighted in accordance with ISO 8041 (1990).

# SAFETY

*This instruction manual must be read with particular attention to the following safety guide lines, by any person servicing or operating this tool.*

## 1. Safety Glossary

 — Product complies with requirements set forth by the relevant European directives.

 — Read manual prior to using equipment.

 — Eye protection required while using this equipment.

 — Hearing protection required while using this equipment.



**WARNINGS - Must be understood to avoid severe personal injury.**

**CAUTIONS** - *show conditions that will damage equipment and or structure.*

**Notes** - are reminders of required procedures.

**Bold, Italic type and underlining** - emphasizes a specific instruction.

2. Huck equipment must be maintained in a safe working condition at all times and inspected on a regular basis for damage or wear. Any repair should be done by a qualified repairman trained on Huck procedures.
3. Repairman and Operator must read manual prior to using equipment and understand any Warning and Caution stickers/labels supplied with equipment before connecting equipment to any primary power supply. As applicable, each of the sections in this manual have specific safety and other information.
4. See MSDS Specifications before servicing the tool. MSDS Specifications are available from you Huck representative or on-line at [www.huck.com](http://www.huck.com). Click on Installation Systems Division.
5. When repairing or operating Huck installation equipment, always wear approved eye protection. Where applicable, refer to ANSI Z87.1 - 1989
6. Disconnect primary power source before doing maintenance on Huck equipment.
7. If any equipment shows signs of damage, wear, or leakage, do not connect it to the primary power supply.
8. Make sure proper power source is used at all times.
9. Never remove any safety guards or pintail deflector.
10. Never install a fastener in free air. Personal injury from fastener ejecting may occur.
11. When using an offset nose always clear spent pintail out of nose assembly before installing the next fastener.
12. If there is a pinch point between trigger and work piece use remote trigger. (Remote triggers are available for all tooling).
13. Do not abuse tool by dropping or using it as a hammer. Never use hydraulic or air lines as a handle. Reasonable care of installation tools by operators is an important factor in maintaining tool efficiency, eliminating downtime, and in preventing an accident which may cause severe personal injury.
14. Never place hands between nose assembly and work piece.
15. Tools with ejector rods should never be cycled with out nose assembly installed.
16. When two piece lock bolts are being used always make sure the collar orientation is correct. See fastener data sheet of correct positioning.

# CONTENTS

<b>EU DECLARATION OF CONFORMITY</b> .....	<b>2</b>
<b>CONTENTS</b> .....	<b>3</b>
<b>SPECIFICATIONS</b> .....	<b>4-5</b>
<b>SAFETY</b> .....	<b>6</b>
<b>PRINCIPLE OF OPERATION</b> .....	<b>7</b>
<b>PREPARATION FOR USE</b> .....	<b>8</b>
<b>SERVICING THE TOOL</b>	
GENERAL, DAILY & WEEKLY .....	<b>8</b>
DISASSEMBLY .....	<b>9-11</b>
ASSEMBLY .....	<b>11-13</b>
FILL AND BLEED .....	<b>13-15</b>
ASSEMBLY DRAWING/PARTS LIST (244) .....	<b>16-17</b>
ASSEMBLY DRAWING/PARTS LIST (244OS) .....	<b>18-19</b>
MEASURING/ADJUSTING TOOL STROKE (244OS) .....	<b>20</b>
ATTACHING NOSE ASSEMBLY (244OS) .....	<b>21</b>
<b>TROUBLESHOOTING</b> .....	<b>22</b>
<b>ACCESSORIES</b> .....	<b>22</b>

# TOOL SPECIFICATIONS

## Model 244

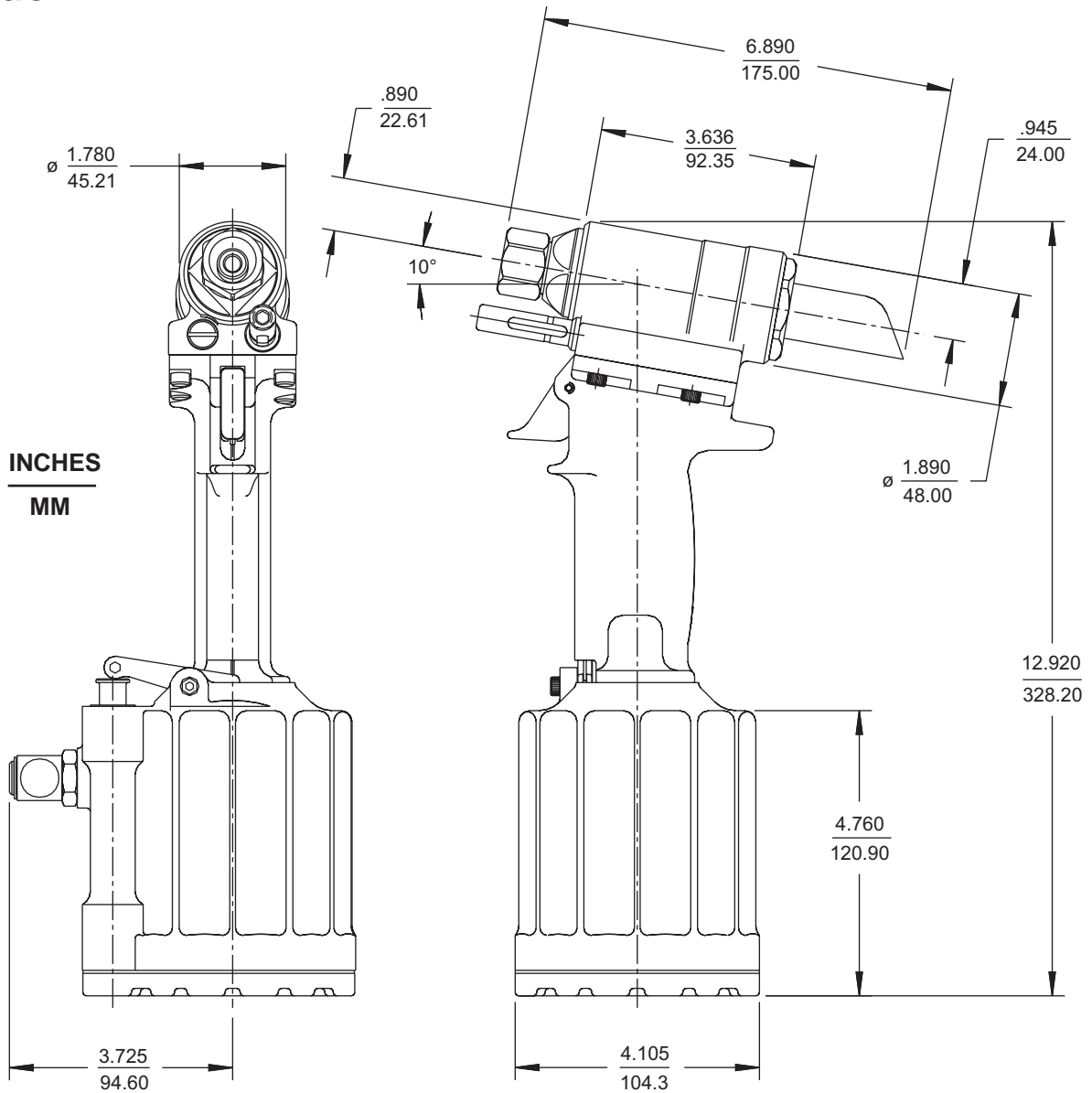

- **Stroke:** .562 in
- **Weight:** 5 lbs 11oz
- **Air Pressure:** 90-100 psi
- **Capacity:** 4606 lbs @ 90 psi
- **Speed/Cycles:** 30 per minute
- **Noise Level:** 75 dBA @ 90 psi

# TOOL SPECIFICATIONS

## Model 244OS

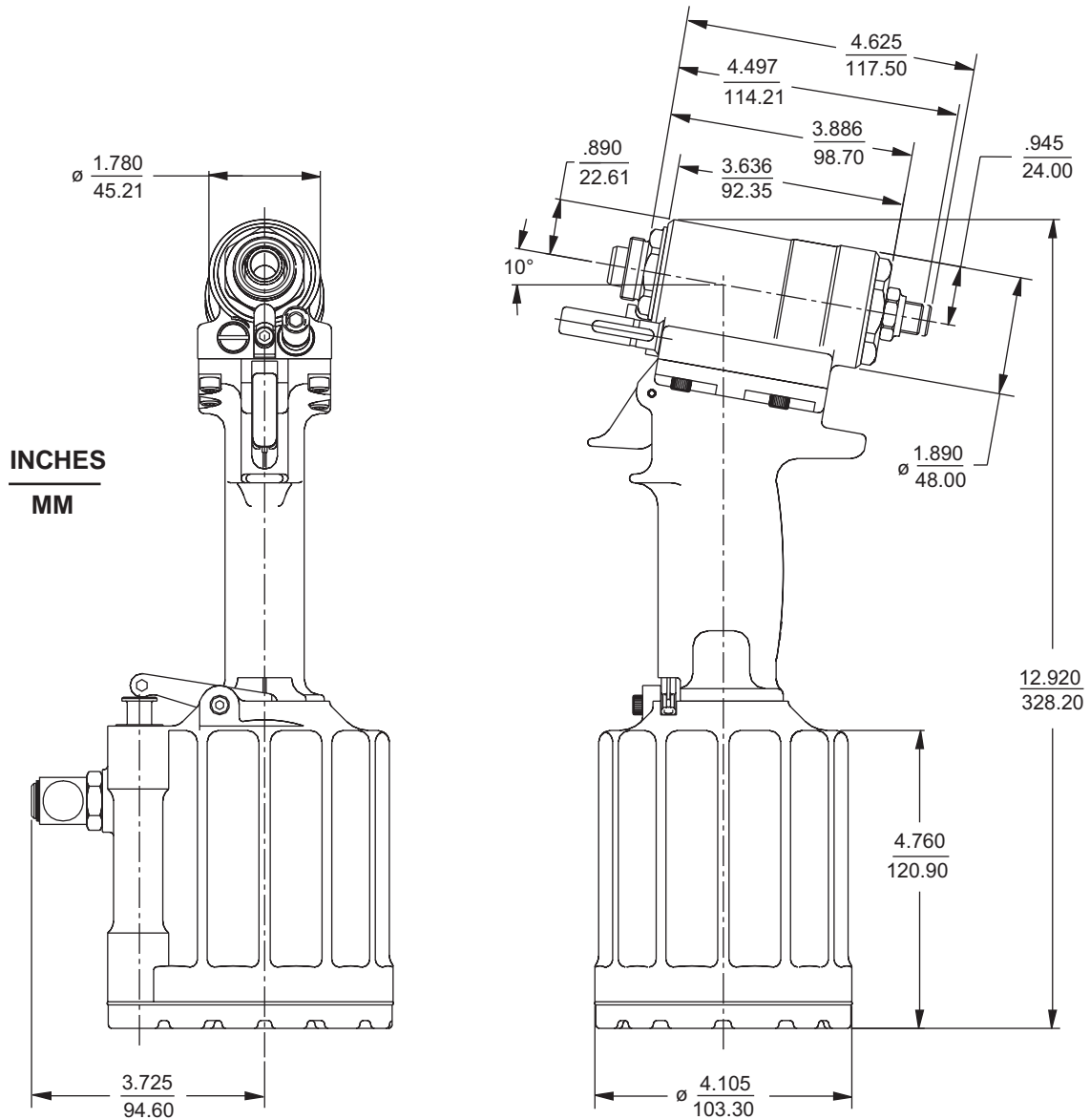

- **Stroke:** Adjustable 0 - .500 in
- **Weight:** 5 lbs 11oz
- **Air Pressure:** 90-100 psi
- **Capacity:** 4606 lbs @ 90 psi
- **Speed/Cycles:** 30 per minute
- **Noise Level:** 75 dBA @ 90 psi

# PRINCIPLE OF OPERATION

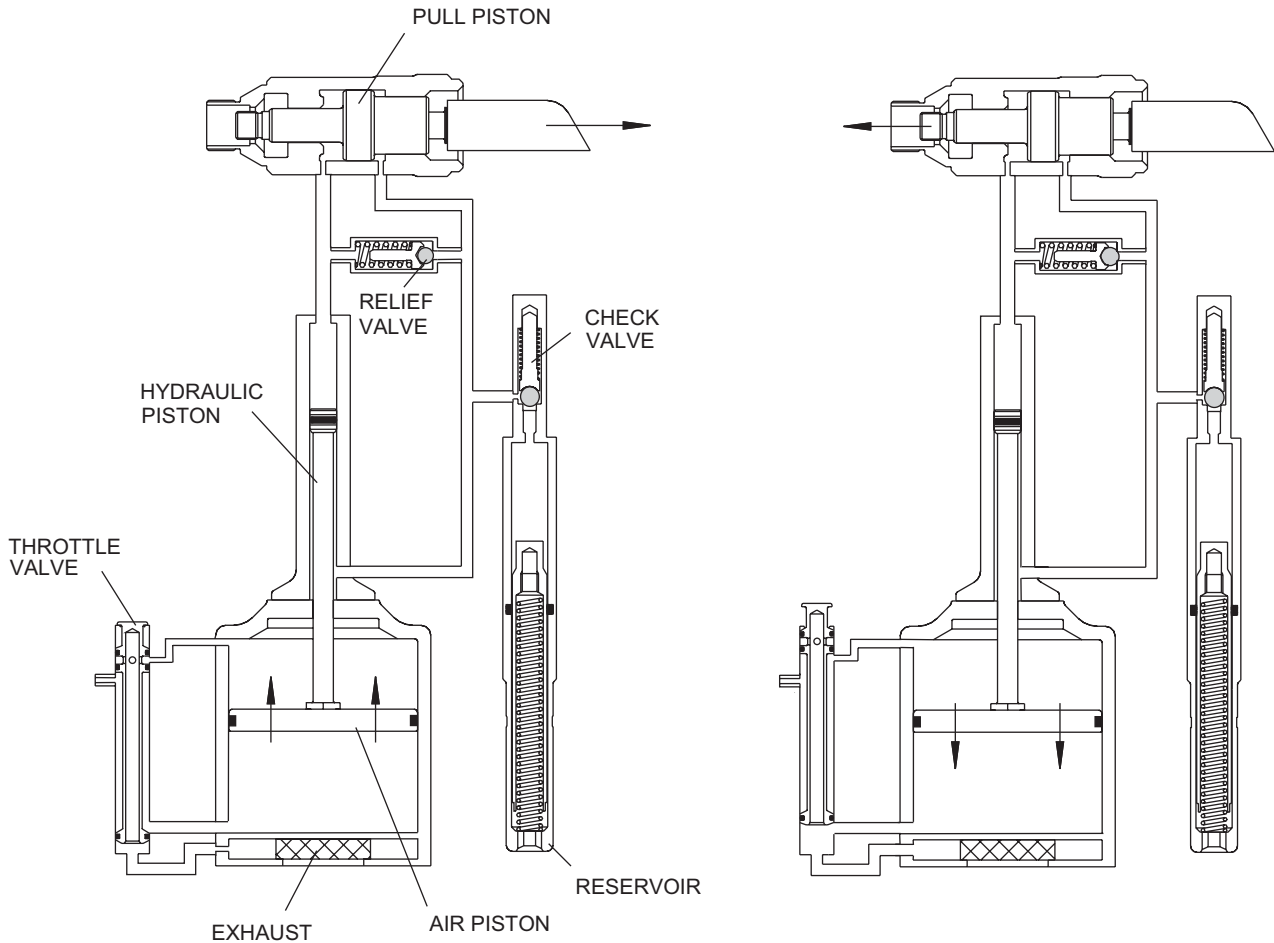

When the trigger is depressed the throttle valve moves to down position, pressurized air is directed to the bottom of the air piston, causing the piston to move upward. The air above the piston is exhausted and directed through the center of the throttle valve and out the bottom of the tool. The air piston has a rod and a hydraulic piston attached. When the air piston rod moves upward, a column of pressurized fluid is forced into head, which moves the pull piston back. The attached nose assembly moves with the pull piston spindle to start fastener installation.

When fastener installation is completed, the trigger is released. Air pressure with the assistance of a spring causes the throttle valve to return to its up position. Pressurized air is re-directed to the top of the air piston, causing the piston to move downward. The air from below the piston is exhausted through bottom of tool. The rod and hydraulic piston move downward; hydraulic pressure is reversed and the pull piston is returned forward. Return pressure relief valve protects tool against pressure spikes. The reservoir replenishes hydraulic system as needed.

# PREPARATION FOR USE

The Model 244/244OS Installation Tool is shipped with a plastic plug in the air inlet connector. The connector has 1/4-18 female pipe threads to accept the air hose fitting. Quick disconnect fittings and 1/4" inside diameter air hose (1) are recommended. An air supply of 90-100 psi capable of 6.3 CFM must be available. Air supply should be equipped with a filter-regulator-lubricator unit.

1. Remove plastic shipping plug from Air Inlet Connector and put in a few drops of Automatic Transmission Fluid, DEXRON III, or equivalent.
2. Screw quick disconnect fitting into Air Inlet Connector.  
**CAUTION:** *Do not use TEFLON tape on threads - - use TEFLON in stick form only.* (Huck P/N 503237)
3. Set air pressure on regulator to 90-100 psi.
4. Attach optional Air Hose (Huck part number 115436), supplied with tool, to air inlet connector.
5. Connect air hose to tool.
6. Cycle tool a few times by depressing and releasing trigger.
7. Disconnect air hose from tool.
8. Remove Retaining Nut and Stop. **(244Only)**

9. Select proper Nose Assembly from **SELECTION CHART** for fastener to be installed.
10. **244OS Model:**  
Set stroke required for Nose Assembly selected. Refer to Adjust Stroke section of this manual for adjustment procedure (**Fig 11**).
11. **244 Model:**  
Attach Nose Assembly per Nose Assembly Data Sheet.  
**244OS Model:**  
**Attach nose assembly per instructions on page 21 of this manual (Fig 12).**
12. Connect air hose to tool and install fastener(s) in test plate of proper thickness with proper size holes. Inspect fastener(s).

## NOTES:

1. Air quick disconnect fittings and air hoses are not available from Huck International, Inc.
2. On old style nose assemblies with lock collars, **VIBRA-TITE** should be used on collet threads, since there is no staking hole provided on the 244 pull piston. Refer to nose assembly data sheets.

# SERVICING THE TOOL

## GENERAL

1. The efficiency and life of any tool depends upon proper maintenance. Regular inspection and correction of minor problems will keep tool operating efficiently and prevent downtime. The tool should be serviced by personnel who are thoroughly familiar with how it operates.
2. A clean, well lit area should be available for servicing the tool. Special care must be taken to prevent contamination of pneumatic and hydraulic systems.
3. Proper hand tools, both standard and special, must be available.
4. All parts must be handled carefully and examined for damage or wear. Always replace Seals, when tool is disassembled for any reason. Components should be disassembled and assembled in a straight line without bending, cocking, or undue force. Disassembly and assembly procedures outlined in this manual should be followed.
5. **Service Parts Kit 244KIT** includes consumable parts and should be available at all times. Other components, as experience dictates, should also be available.



**WARNING: Inspect tool for damage or wear before each use. Do not operate if damaged or worn, as severe personal injury may occur**

## DAILY

1. If a Filter-Regulator-Lubricator unit is not being used, uncouple air disconnects and put a few drops of Automatic Transmission Fluid or light oil into the air inlet of the tool. If the tool is in continuous use, put a few drops of oil in every two to three hours.
2. Bleed the air line to clear it of accumulated dirt or water before connecting air hose to the tool.
3. Check all hoses and couplings for damage or air leaks, tighten or replace if necessary.
4. Check the tool for damage or air/hydraulic leaks, tighten or replace if necessary.
5. Check the nose assembly for tightness or damage, tighten or replace if necessary.
6. Check oil level in tool reservoir, replenish if necessary.

## WEEKLY

1. Disassemble and clean nose assemblies and reassemble per applicable NOSE ASSEMBLY DATA SHEET.
2. Check the tool and all connecting parts for damage or oil/air leaks, tighten or replace if necessary.



## Model 244/244OS Disassembly/Assembly



**WARNING:** Be sure air hose is disconnected from tool before cleaning, or performing maintenance. Severe personal injury may occur if air hose is not disconnected.

For component identification and Parts list refer to Figures ( 9 & 10 ).

### DISASSEMBLY

(Refer to Figures 1-3 and 9 & 10)

**NOTE:**

The following procedure is for complete disassembly of tool. Disassemble **only** components necessary to replace damaged O-rings, Quad-Rings, Back-up Rings, and worn or damaged components. Always use soft jaw vice to avoid damage to tool.

1. Disconnect air hose from tool.
2. Remove nose assembly. Follow instructions on Nose Assembly Data sheet.
3. Insert Fill Tool, P/N 112465 through reservoir housing and screw into Reservoir Plunger (73) locking it in the out position (Fig1).
4. Unscrew Cap Screws (69) with 5/32 hex key. Carefully lift Head straight up from Handle (1), remove Pull Gland Assembly (29) and Return Gland Assembly (25) from separated head and handle assemblies (Fig1).
5. Unscrew Plug (85) of return Pressure Relief Valve from front of head. Remove Spring (84), valve Guide (82), Sleeve (83) and Steel Ball (81). A small magnet is helpful (Fig1).
6. Unscrew Bleed Plug (40). Hold over waste oil container and release fill tool slowly (Fig1).
7. Unscrew Housing/Spacer Assembly (70) from head. Remove two Springs (2x 71 for the 244 tool or 71 & 93 for the 244OS tool). Slide Reservoir Plunger (73) from head. Remove spacer and Quad-Ring (72), a pick may be used to remove the Quad-Ring (Fig1).
8. Unscrew Plug (78) of reservoir check valve from side of head. Remove Spring (77), Check Valve Guide (76) and Stainless Steel Ball (75) (Fig1).
9. 244 Model Only (Fig. 1 & 9) Pintail Deflector (22) can be pulled off deflector tube at rear of Piston.

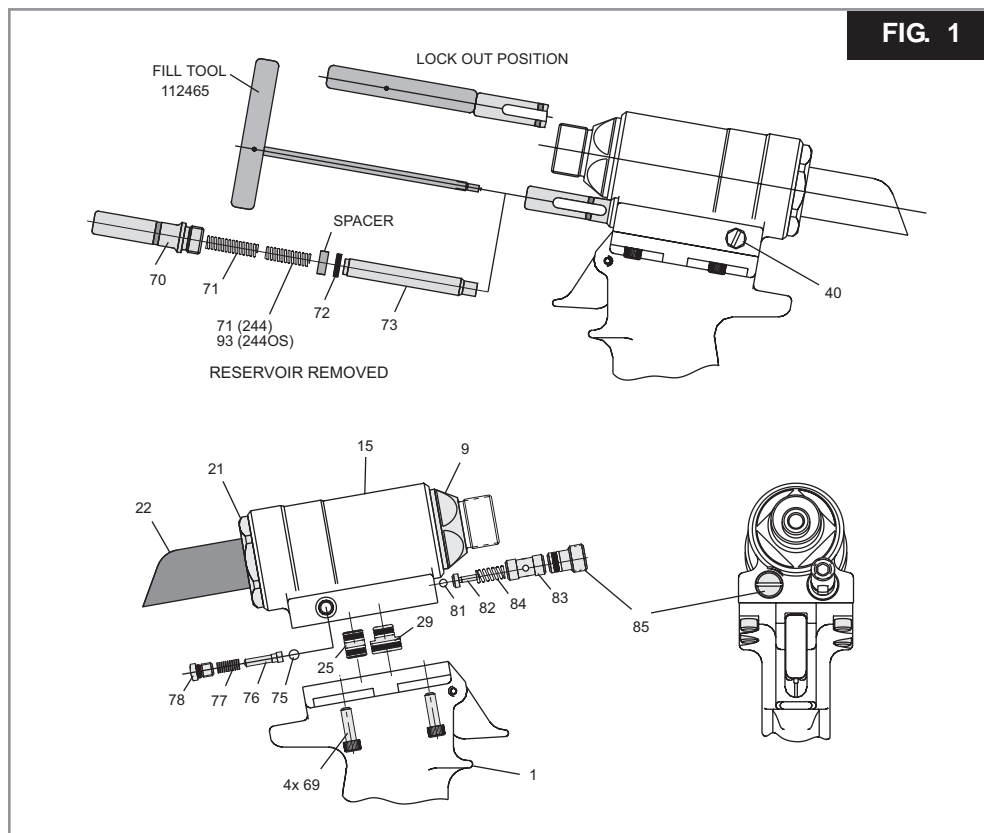

10. 244 Model: (Fig. 1 & 9)

Unscrew End Cap (21) from Head, Plug & Seat Assembly (15) with 1 9/16 open end wrench.

244OS Model: (Fig. 10)

Loosen and remove Locknut (92) from Piston Stop (89). Unscrew Piston Stop (89) from End Cap (21), then unscrew End Cap from Head, Plug & Seat Assembly (15) with 1 9/16 open end wrench.

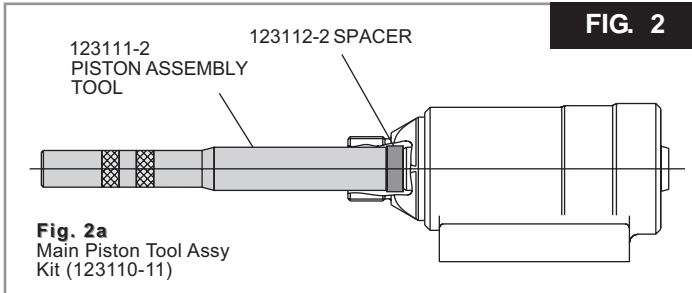

**Fig. 2a**  
Main Piston Tool Assy  
Kit (123110-11)

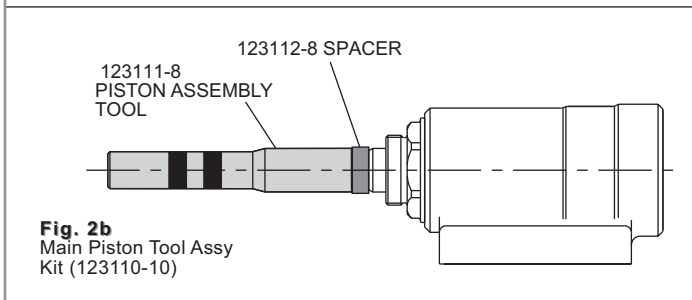

**Fig. 2b**  
Main Piston Tool Assy  
Kit (123110-10)

11. 244 Model: (Fig. 2a)

Place Spacer (123112-2) on piston and thread on Piston Assembly Tool (123111-2) onto piston. Tap or press piston assembly out of head.

**NOTE:** Piston will push out front and rear gland assembly.

244OS Model: (Fig. 2b)

Place Spacer (123112-8) on piston and thread on Piston Assembly Tool (123111-8) onto piston. Tap or press piston assembly out of head.

**NOTE:** Piston will push out front and rear gland assembly.

12. Remove Nose Adapter (9) from front of Head, Plug & Seat Assembly (15). (Figs. 1 & 9) (Fig. 10 for 244OS Model).

13. If Seat (74) is damaged, contact your Huck representative. If Seat Assembly (80) is damaged, it can be removed by using Seat Removal Tool (126136) optionally available.

**NOTE:** Seats should not be reused. They should be replaced.

14. With a small punch and hammer, drive Roll Pin (4) that retains the Trigger (5) from the Handle (1). Remove Trigger Pin (3). Remove ball cable end from Throttle Arm (68) and pull Cable Assembly (2) out of Handle (1). (Fig. 3)

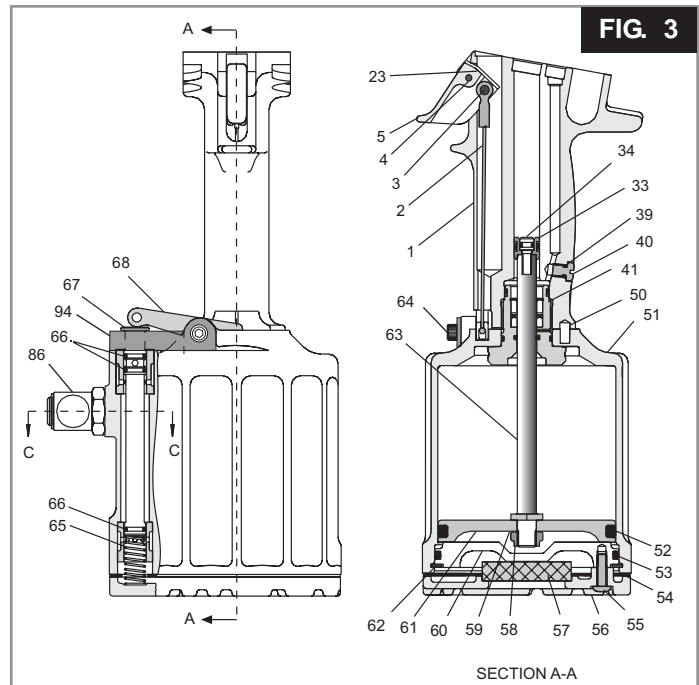

15. Remove Pivot Screw (64) and Lever Guard (94) from Throttle Arm (68). Remove Throttle Arm. Pull Throttle Valve (67) out of cylinder. Remove Spring (65) (Fig3).

16. Remove Bleed Plug (40) from handle (Fig3).

17. Hold tool inverted in vice. Unscrew three Button Head Screws (55) with 1/8 hex key (Fig3).

18. Remove Bottom Plate (56), Gasket (54) and Muffler (57) (Fig3).

19. Remove Retaining Ring (62) from Cylinder Assembly (51) (Fig3).

20. Install Screws (55) into Cylinder Head (60). Carefully pry under screws to remove cylinder head.

21. Push air piston all the way down in cylinder, lay tool on its side. Hold Locknut (58) with a 9/16 socket and extension and with 7/64 hex key, remove piston Screw (34).

22. Grip Locknut (58) under Air Piston with pliers and pull piston and rod assembly from handle and cylinder assembly.

**CAUTION:** Care must be taken not to scratch piston rod or cylinder during removal.

24. Turn cylinder and handle upside down and secure in a vise.

25. With a 1 3/8 socket and extension, remove Gland Assembly (41). Handle and cylinder will now separate (Fig3).

26. Push Piston Assembly (33) out of handle. Push out from top to bottom.

**CAUTION:** A plastic or wooden drift must be used to avoid damaging the handle bore.

27. Remove Swivel Assembly (86) from cylinder. Swivel Assembly may be disassembled to replace seals (32 & 87) if necessary. (Fig. 9)

28. To remove Polyseal (43) from Gland Assembly (41), Remove Retaining Ring (45) and Spacer (44). (Fig. 9)

## ASSEMBLY

(See Figures 4 thru 7 and 9.)

Clean components with mineral spirits, or similar solvent; inspect for wear/damage and replace as necessary.

Replace all seals of disassembled components. Use O-rings, Quad-Rings and Back-up rings in **Service Parts Kit, P/N 244KIT**. Smear LUBRIPLATE 130AA or PARKER-O-LUBE on O-rings, Quad-Rings, Back-up rings and mating parts to ease assembly. Assemble tool taking care not to damage O-rings, Quad-Rings, or Back-up rings.

1. Holding handle inverted in a vice, install Piston Assembly (33) (with O-ring (35) and Back-up rings (36) in place) in handle. \*Press in from bottom of handle taking care not to damage seals. (Fig. 4)

**\*Must be pressed in from bottom of handle to avoid Damaging seals.**

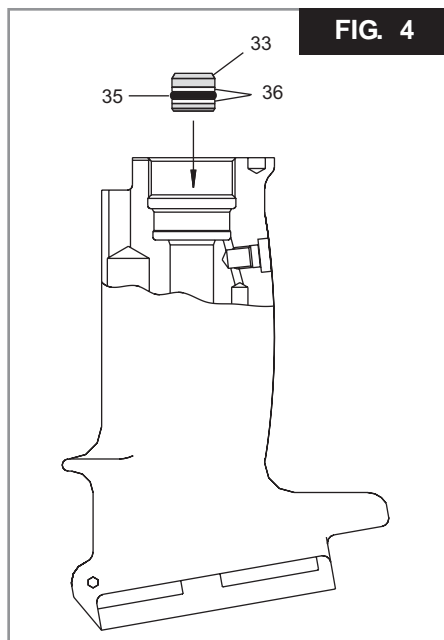

2. Place Cylinder Assembly (51) on handle with Timing Pin (50) positioned in matching hole. Assemble Gland Assembly (41) (See Fig. 9). Screw complete Gland assembly into handle. Torque to 75-80 ft. lbs. using a 1 3/8 socket wrench. (Fig 5)

3. Push Piston Rod (63) through Air Piston (61) from flat side. Drop Washer (59) over thread and screw Locknut (58) onto rod. Hold hex of rod with 9/16 wrench, and torque nut using 9/16 socket to 28 - 32 ft. lbs. (Fig 5).

**CAUTION:** Do not scratch piston rod.

4. Push assembled Air Piston and Rod into Air Cylinder and Gland Assembly (41) until it stops. Push Screw (34) with o-ring in place through hydraulic Piston Assembly (33) and screw into top of piston rod. Hold Locknut (58) with 9/16 socket and extension and torque Screw (34) using 7/64 hex key to 55 - 60 in. lbs.

5. Push Cylinder Head (60) with O-ring (53) in place squarely into cylinder. Install Retaining Ring (62). (Fig. 6)

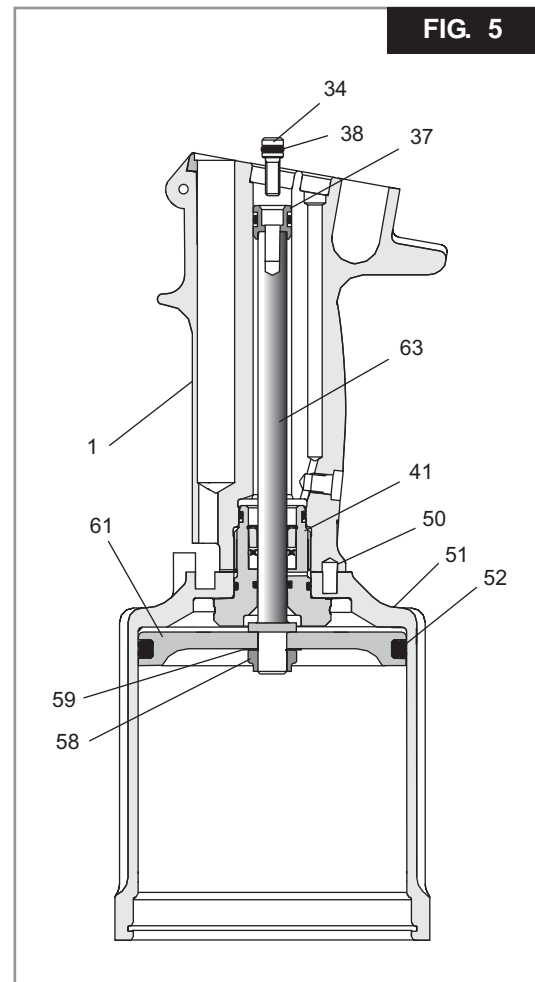

6. Hold handle in vise with bottom facing up. Position Muffler (57) on center of Cylinder Head (60), Place Gasket (54) on Cylinder Assembly (51), place Bottom Plate (56) on top of Gasket and secure with 3 Button Head Screws (55) using 1/8 hex key. (Fig. 6)
7. Turn tool upright. Drop Spring (65) into Throttle valve hole in cylinder. Push Throttle Valve (67) with O-rings (66) in place into cylinder. (Fig. 6)
8. Assemble Trigger (5), Cable Assembly (2) and Trigger Pin (3) together and slide cable into Handle (1). Align hole in Trigger and hole in handle ears and install Roll Pin (4) with a hammer and punch. (Fig. 6)
9. Slide Throttle Arm (68) onto ball end of Throttle Cable. Swing arm until other end fits over throttle valve. Place Lever Guard (94) over Throttle Arm and install Pivot Screw (64) through Throttle Arm . Tighten with 5/32 hex key.
10. Install Swivel Assembly (86) in Cylinder Assembly (51). (Fig. 9)

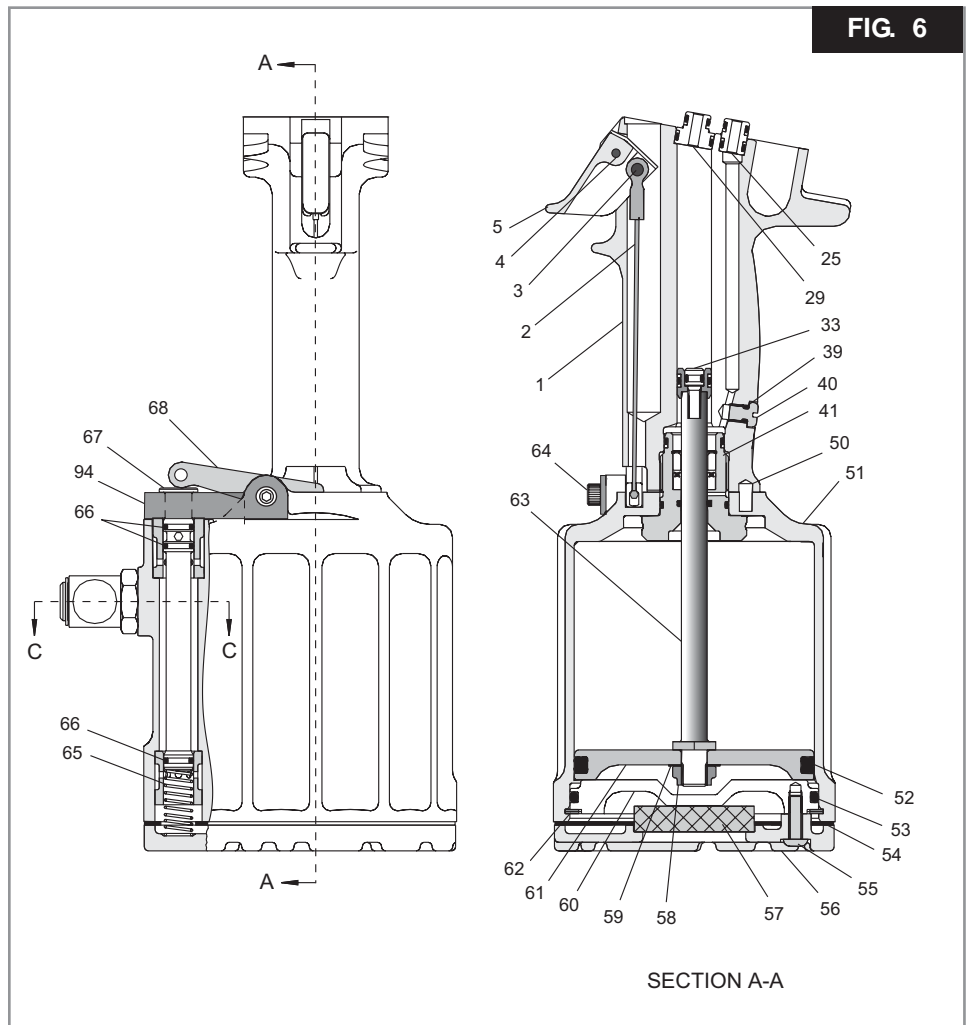

11. If Air Hose 115436 was removed, reinstall in swivel assembly.
12. If Seat Assembly (80) is being replaced push in seat and seal assembly using soft drift taking care not to damage ball seat surface. (Fig. 9)
13. Assemble hydraulic Piston (18) with new seals (16,17). Lubricate with LUBRIPLATE or PARKER SUPER-O-LUBE. (Fig. 9)
14. Install Nose Adapter (9) on front of head. (Use VIBRA-TITE Huck P/N 505125 on threads). Torque to 50-60 ft. lbs. (Fig. 7)
15. Assemble Front Gland (12) Gland Cap (11) O-ring (14) Back-up Ring (13) and Polyseal (6). Thread Piston Assembly Tool 123111-2 (244), 123111-8 (244OS) onto

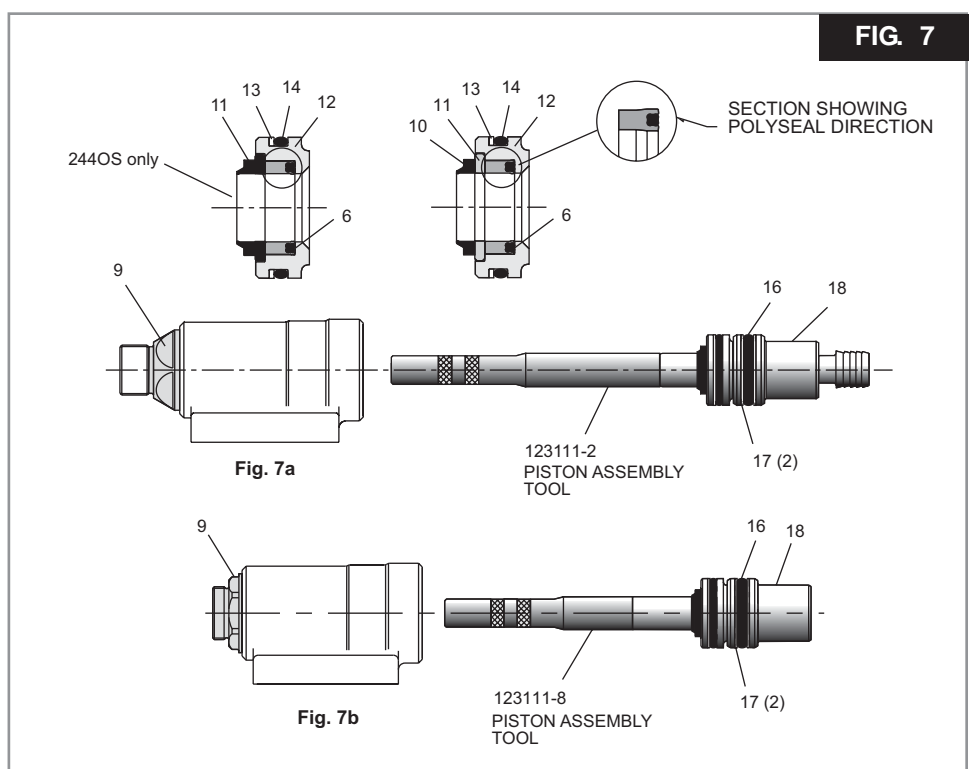

- Piston (18). Slide complete Front Gland Assembly and (Wiper Seal (10) 244 only) over Piston Assembly Tool onto Piston. (Fig. 7)
16. Press entire piston and gland assembly into head. Remove Piston Assembly Tool from piston. (Fig. 7)
  17. 244 Model: (Fig. 9)  
Place Seals (20) and (24) on Rear Gland (19). Push complete assembly into head and screw in End Cap (21), and torque to 50 - 60 ft. lbs.
  - 244OS Model: (Fig. 10)  
Place seals (20 & 24) on Rear Gland (19). Push complete assembly into head and screw in End Cap (21), torque to 50 - 60 ft. lbs. Thread Stop (89) into End Cap (21) two turns, thread Locknut (92) onto Piston Stop (89) and leave loose. For adjustment, refer to **Measuring Tool Stroke** section of this manual (Page 20).
  18. Install Quad-Ring (72) and Spacer. Slide Reservoir Plunger (73) in. {244OS Model: Install Spring (93) first, then Spring (71); 244 Model: Install two Springs (71)}. Screw Housing/Spacer Assembly into head. (Fig. 1)
  19. 244 Model Only (Fig. 1 & 9)  
Push Pintail Deflector (22) onto rear of Piston (18).
  20. Place O-ring (39) on Plug (40) and screw assembly into Handle (1). (Fig. 6)
  21. Install Pull (29) and Return (25) Gland Assemblies in handle. Push head down on glands. Place tool in a vise Head down and install 4 Screws (69) and torque to 170 inch pounds. (Fig. 6 & 9)
  22. Tool is now completely assembled except for relief and check valves. See fill and bleed procedure for replacement of valve components.

## FILL AND BLEED 244/244OS (Fig. 8)

### Equipment Required:

- Shop airline with 90-100 psi max.
- Air regulator
- Fill Bottle 120337 (supplied with tool).
- Fill Tool Assy 112465 (244)
- Fill Tool Assy 112465 (244OS)
- Large flat blade screwdriver
- Stall Nut 124090 (244)

### Preparation:

1. Install air regulator in airline and set pressure to 20-40 psi.
2. Fill bleed bottle almost full of DEXRON III - ATF (automatic transmission fluid) (See Fig. 8.)

*Refill tool only when red line on plunger drops below the red line on the reservoir housing or when tool is rebuilt.*  
**REFILL: AUTOMATIC TRANSMISSION FLUID DEXRON III, OR EQUIVALENT.**

### Step 1

Screw Fill Tool P/N 112465 into Reservoir Plunger, pull Plunger into Housing and lock Fill Tool in full forward position by tilting handle (long side touching tool) and locking in place.

### Step 2

Remove Relief Valve and Check Valve plugs, guides, springs and balls from ports in head. Reinstall Plug (85) and sleeve (83) in head in Relief Valve port (front of tool).

### Step 3

244 Model (Fig. 8)

Screw retaining nut onto Head Assembly. Screw Stall Nut onto Piston and tighten to ensure full thread engagement. Back off retaining nut until it engages stall nut. Check Piston location. *Piston must be all the way forward and locked with stall nut and retaining nut.*

244OS Model (Fig. 8)

Loosen Locknut (92). Screw Piston Stop (89) in until it pushes and holds the piston in the full forward position. *Piston must be all the way forward and locked in place with Stop.*

### Step 4

Attach the tool air source momentarily to seat air piston at bottom of cylinder - disconnect tool. With fill port facing up, (check valve on side) lay tool on its side (See Fig. 8).

### Step 5

Install fill bottle in head fill port (check Valve hole) (See Fig. 8).

### Step 6

Connect tool to shop air 20 to 40 psi. Cycle tool 20-30 times, watch for air bubbles escaping from the tool into bottle. (You may rock the tool to free trapped air in the tool.) Do not allow the air to re-enter the tool. When cycling tool, always hold bottle up as shown in Figure 8 to prevent drawing in air from empty part of bottle.



**WARNING: Air pressure MUST be set to 20 to 40 psi to prevent possible injury from high pressure spray. If plug (78) is removed, fill bottle must be in place before cycling tool.**

### Step 7

When air bubbles no longer appear in bottle, remove fill bottle while tool is lying on its side.

### Step 8

Install the check valve Ball (75), Check Valve Guide (76) and Spring (77). Replace the Plug (78).

**Step 9**

Turn tool so front of head faces you and remove the relief valve Plug (85) and install relief valve Ball (81), Guide (82), Sleeve (83) and Spring (84). Replace the Plug (85).

**Step 10**

244 Model (Fig. 8)

Unlock Fill Tool and check Reservoir red line. At this point cycle the tool the with Stall Nut attached and retaining nut locked in the full forward position ("Dead Stall"). Reservoir should not drop below the red line on the reservoir housing.

244OS Model (Fig. 8)

Unlock Fill Tool and check Reservoir red line. At this point cycle the tool with the Stop still holding the piston in the full forward position ("Dead Stall"). Reservoir should not drop below the red line on the reservoir housing.

**Step 11**

Re-lock the fill tool. Lay tool on its left side and remove Plug (40). Top off reservoir by placing a few drops of oil in hole and waiting for air bubbles to escape. Push a pin or a scribe into hole to check for trapped air bubbles. Replace plug.



**WARNING - Failure to re-lock the fill tool will result in oil being ejected from the head under pressure during the topping off of the reservoir. Severe personal injury may result.**

**Step 12**

Unlock the fill tool and cycle tool as in step 10. Reservoir may drop slightly. If so, repeat step 11 until when you touch the fill tool handle, it has no pressure against it and it drops out of the lock position, and the plunger does not drop when tool is cycled. **NOTE:** This usually requires 3 to 4 times topping off.

**Step 13**

244 Model (Fig. 8)

Remove fill tool and stall nut. Install a nose assembly and pull several fasteners to test function.

244OS Model (Fig. 8)

Remove fill tool. Adjust the tools stroke for the Nose Assembly being used by threading out Piston Stop (89). Refer to **Measuring Tool Stroke** section for the stroke adjustment procedure.

## ----- SERVICE NOTES: -----

FILL AND BLEED

FIG. 8

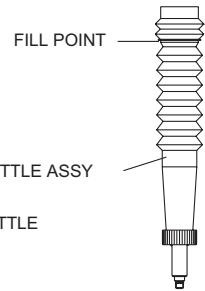
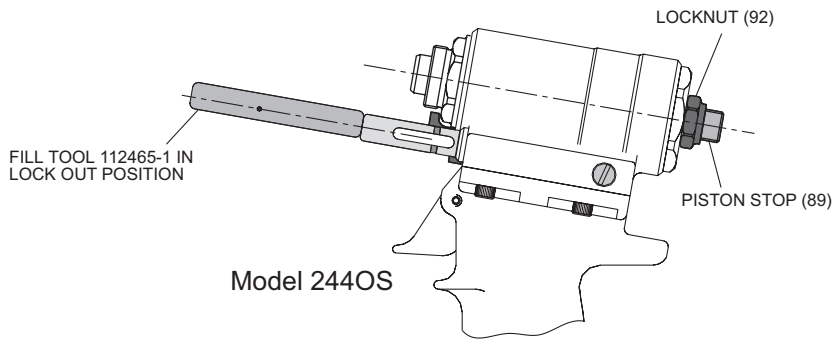
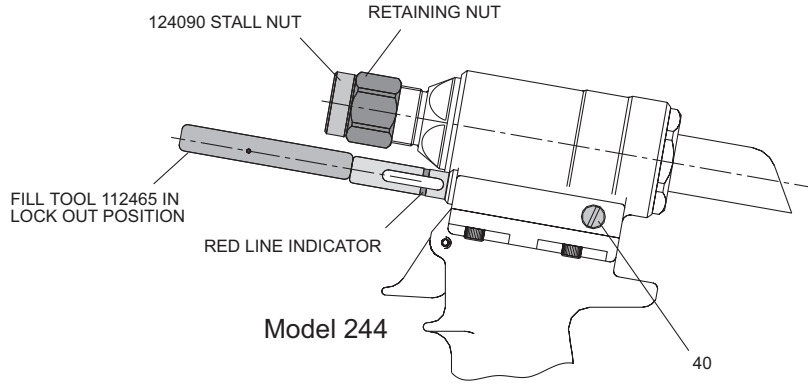

INCLUDES:  
120336 FILL BOTTLE  
120004 CAP

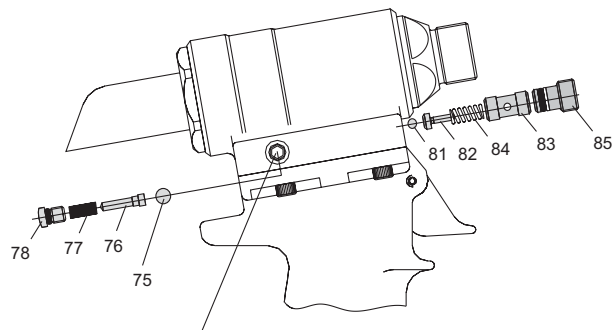

INSTALL FILL & BLEED  
BOTTLE HERE  
(CHECK VALVE HOLE)

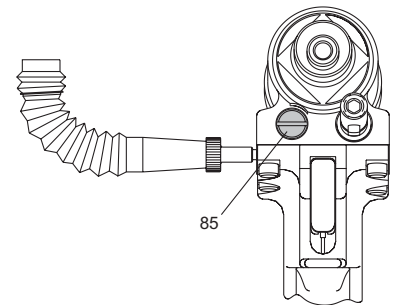

ASSEMBLY DRAWING 244

FIG. 9

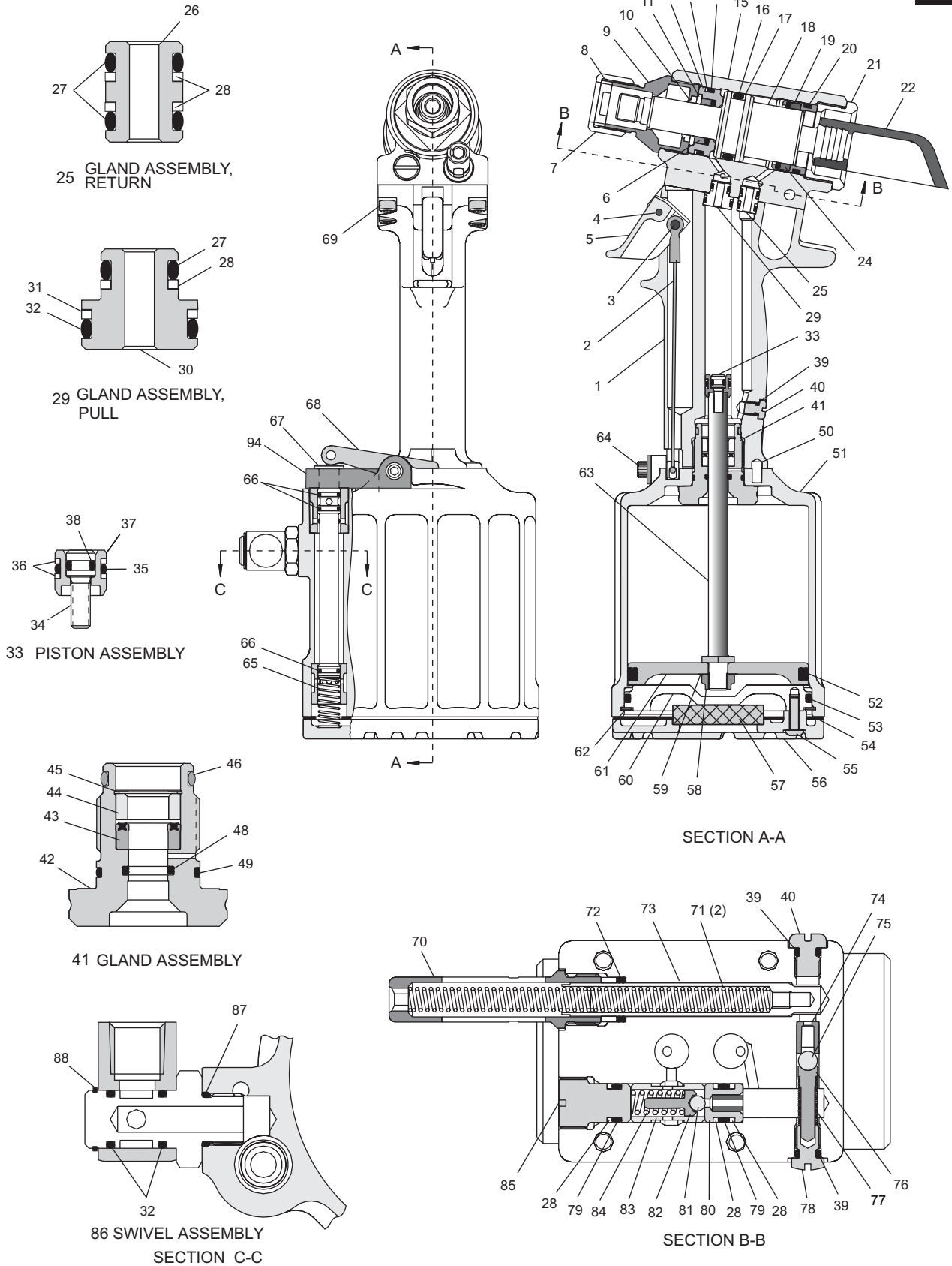



## PARTS LIST 244

ITEM	PART#	DESCRIPTION	QTY	ITEM	PART#	DESCRIPTION	QTY
1	125550	Handle	1	46	500812	O-Ring	1
2	116404-1	Cable Assembly	1	47	-----	-----	---
3	505496	Trigger Pin	1	48	501074	Quad-Ring	1
4	500621	Roll Pin	1	49	500786	O-Ring	1
5	124333-1	Trigger	1	50	505496	Timing Pin	1
6	505818	Polyseal	1	51	125560	Cylinder Assembly	1
7	111795	Retaining Nut	1	52	501456	Quad-Ring	1
8	120588	Stop	1	53	500869	O-Ring	1
9	125537	Nose Adapter	1	54	125724-1	Gasket	1
10	505817	Wiper Seal	1	55	504127	Screw	3
11	122432	Gland Cap	1	56	116585-1	Bottom Plate	1
12	125538	Front Gland	1	57	115554-1	Muffler	1
13	501113	Back-Up Ring	1	58	505420	Locknut	1
14	500819	O-Ring	1	59	506493	Washer	1
15	125535	Head, Plug, & Seat Assy	1	60	111959-1	Cylinder Head	1
16	507401	O-Ring	1	61	123753	Air Piston	1
17	501142	Back-Up Ring	2	62	506490	Retaining Ring	1
18	125885	Hydraulic Piston	1	63	125561	Piston Rod	1
19	125543	Rear Gland	1	64	125118	Pivot Screw	1
20	500820	O-Ring	1	65	116272	Spring	1
21	125545	End Cap	1	66	507396	O-Ring	3
22	124211	Pintail Deflector	1	67	125562	Throttle Valve	1
23	-----	-----	---	68	123754	Throttle Arm	1
24	507400	Polyseal	1	69	500062	Screw	4
25	125555	Return Gland Assembly	1	70	112403	Housing/Spacer Assembly	1
26	125554	Gland Housing	1	71	505864	Spring	2
27	500776	O-Ring	3	72	501408	Quad-Ring	1
28	501082	Back-Up Ring	6	73	112405	Reservoir Plunger	1
29	125553	Pull Gland Assembly	1	74	111139	Seat	1
30	125552	Pull Gland Housing	1	75	502929	Ball	1
31	501085	Back-Up Ring	1	76	111067	Check Valve Guide	1
32	500779	O-Ring	3	77	100874	Spring	1
33	118865	Piston Assembly	1	78	111068	Plug	1
34	117773	Screw	1	79	505446	O-Ring	2
35	503768	O-Ring	1	80	126134	Seat Assembly	1
36	501084	Back-Up Ring	2	81	502506	Ball	1
37	117774	Piston	1	82	120128	Guide	1
38	500773	O-Ring	1	83	120127	Sleeve	1
39	505438	O-Ring	3	84	507403	Spring	1
40	100309	Plug	2	85	114530	Plug	1
41	125557	Gland Assembly	1	86	507164	Swivel Assembly	1
42	126312	Gland/O-ring Assembly	1	87	500778	O-Ring	1
43	506611	Polyseal	1	88	502274	Retaining Ring	1
44	123904	Spacer	1	94	125117	Lever Guard	1
45	505939	Retaining Ring	1				

ASSEMBLY DRAWING 244OS

FIG. 10

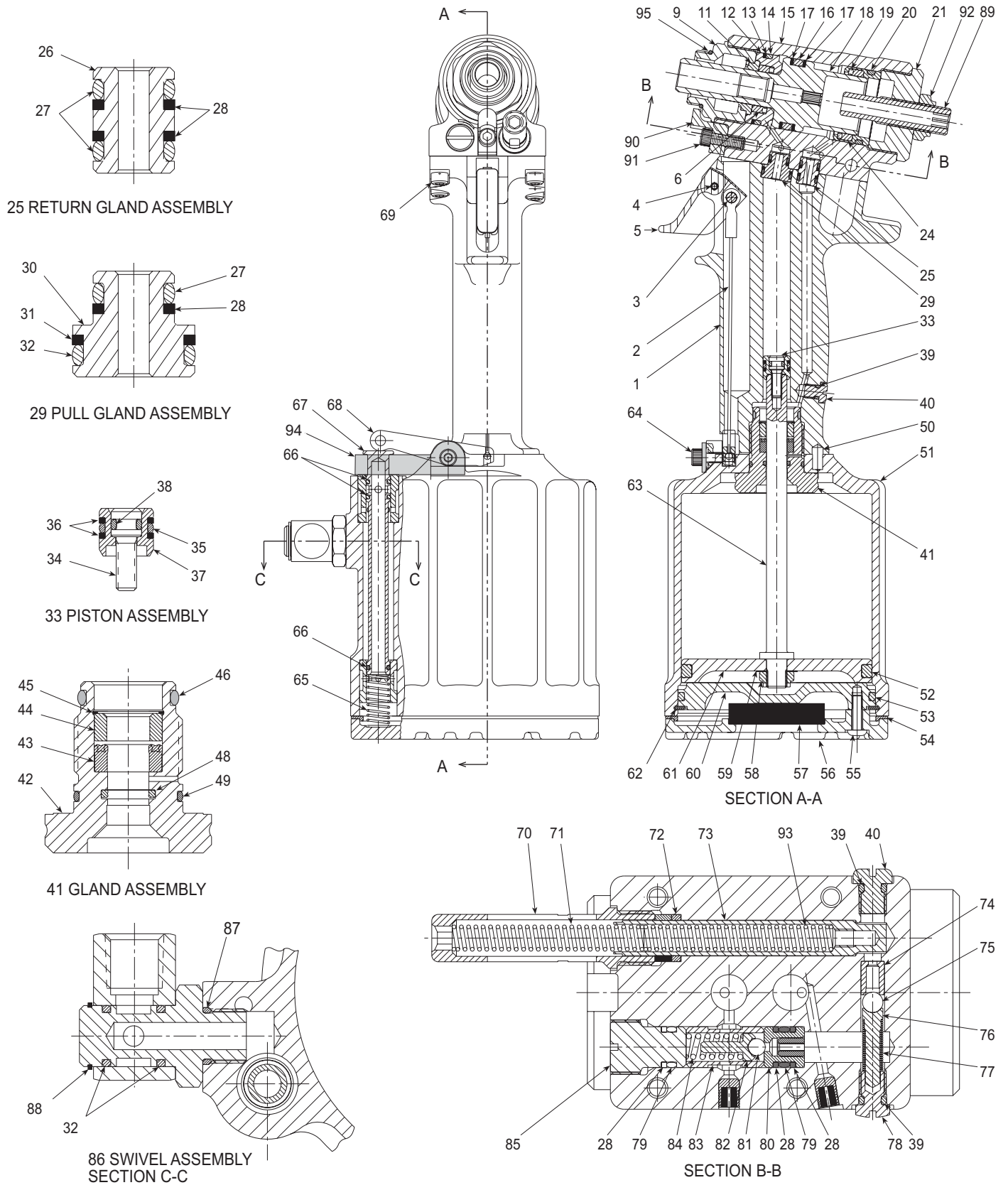

## PARTS LIST 244OS

ITEM	PART#	DESCRIPTION	QTY	ITEM	PART#	DESCRIPTION	QTY
1	125550	Handle	1	49	500786	O-Ring	1
2	116404-1	Cable Assembly	1	50	505496	Timing Pin	1
3	505496	Trigger Pin	1	51	125560	Cylinder Assembly	1
4	500621	Roll Pin	1	52	501456	Quad-Ring	1
5	124333-1	Trigger	1	53	500869	O-Ring	1
6	505818	Polyseal	1	54	125724-1	Gasket	1
7	-----	-----	----	55	504127	Screw	3
8	-----	-----	----	56	116585-1	Bottom Plate	1
9	125947	Nose Adapter	1	57	115554-1	Muffler	1
10	-----	-----	----	58	505420	Locknut	1
11	126323	Gland Cap/Bearing	1	59	506493	Washer	1
12	126530	Front Gland	1	60	111959-1	Cylinder Head	1
13	501113	Back-Up Ring	1	61	123753	Air Piston	1
14	500819	O-Ring	1	62	506490	Retaining Ring	1
15	125535	Head, Plug, & Seat Assy	1	63	125561	Piston Rod	1
16	507401	O-Ring	1	64	125118	Pivot Screw	1
17	501142	Back-Up Ring	2	65	116272	Spring	1
18	125946	Hydraulic Piston	1	66	507396	O-Ring	3
19	125543	Rear Gland	1	67	125562	Throttle Valve	1
20	500820	O-Ring	1	68	123754	Throttle Arm	1
21	125948	End Cap	1	69	500062	Screw	4
22	-----	-----	----	70	112403-1	Housing/Spacer Assembly	1
23	-----	-----	----	71	505864	Spring	1
24	507400	Polyseal	1	72	501408	Quad-Ring	1
25	125555	Return Gland Assembly	1	73	112405	Reservoir Plunger	1
26	125554	Gland Housing	1	74	111139	Seat	1
27	500776	O-Ring	3	75	502929	Ball	1
28	501082	Back-Up Ring	6	76	111067	Check Valve Guide	1
29	125553	Pull Gland Assembly	1	77	100874	Spring	1
30	125552	Pull Gland Housing	1	78	111068	Plug	1
31	501085	Back-Up Ring	1	79	505446	O-Ring	2
32	500779	O-Ring	3	80	126134	Seat Assembly	1
33	118865	Piston Assembly	1	81	502506	Ball	1
34	117773	Screw	1	82	120128	Guide	1
35	503768	O-Ring	1	83	120127	Sleeve	1
36	501084	Back-Up Ring	2	84	507403	Spring	1
37	117774	Piston	1	85	114530	Plug	1
38	500773	O-Ring	1	86	507164	Swivel Assembly	1
39	505438	O-Ring	3	87	500778	O-Ring	1
40	100309	Plug	2	88	502274	Retaining Ring	1
41	125557	Gland Assembly	1	89	125949	Piston Stop	1
42	126312	Gland/O-ring Assembly	1	90	125951	Rotational Stop	1
43	506611	Polyseal	1	91	500102	Cap Screw	1
44	123904	Spacer	1	92	501071	Locknut	1
45	505939	Retaining Ring	1	93	507602	Spring	1
46	500812	O-Ring	1	94	125117	Lever Guard	1
47	-----	-----	----	95	500784	O-Ring	1
48	501074	Quad-Ring	1				

## MEASURING/ADJUSTING TOOL STROKE (244OS)

FIG. 11

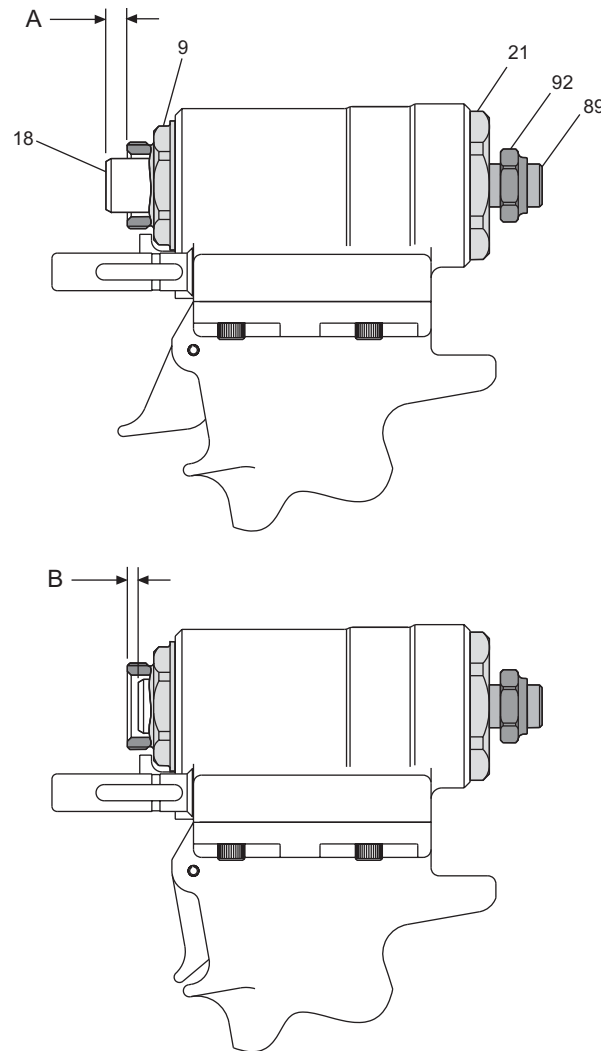
**ADJUSTING STROKE**

1. Measure distance "A" from face of Hydraulic Piston (18) to face of Nose Adapter (9). This distance should be approximately equal to .247 inches.
2. Cycle tool and hold piston back by keeping the trigger depressed. Measure distance "B" as above.
3.  $STROKE = A+B$
4. Adjust Piston Stop (89) clockwise to reduce dimension "B" (decreasing stroke) and counterclockwise to increase "B" (increasing stroke). Repeat step 2.
5. When desired stroke has been reached, hold Piston Stop (89) with a ¼" hex key and with a ¾" open end wrench tighten Locknut (92) against End Cap (21).

## ATTACHING NOSE ASSEMBLY (244OS)

FIG. 12

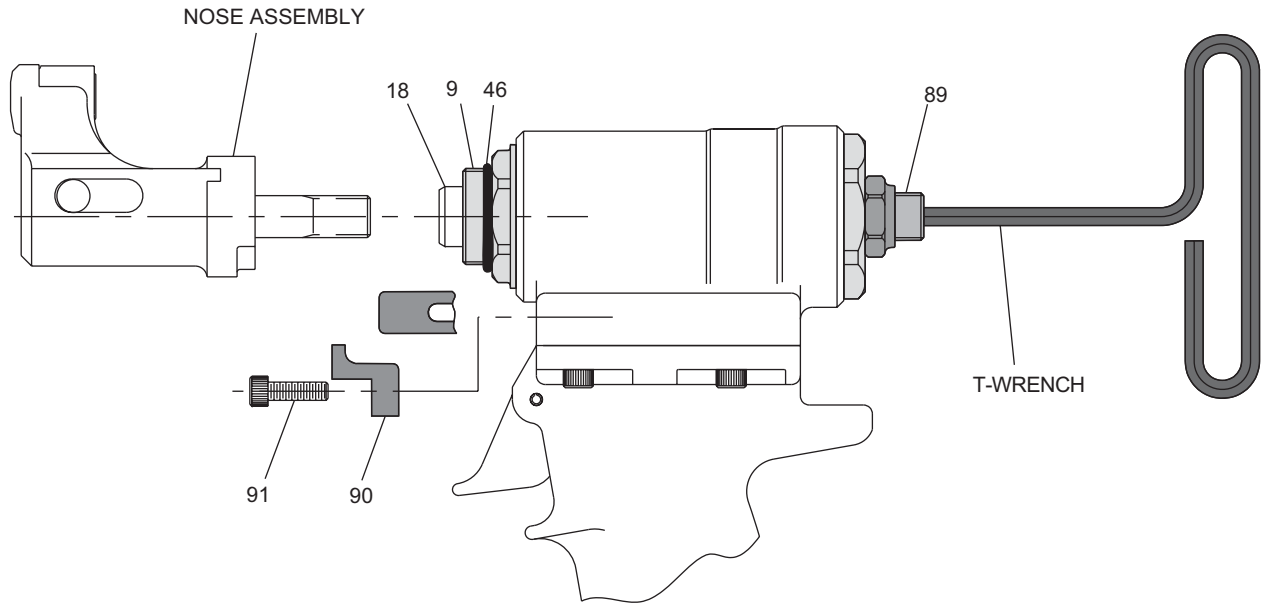
**ATTACHING NOSE ASSEMBLY**

1. Remove Cap Screw (91) and Rotational Stop (90).
2. Insert a 3/16" hexagonal T-Wrench through Piston Stop (89) until it engages the internal hex in Hydraulic Piston (18).
3. Thread the nose assembly onto the tool until it bottoms out. Then back it off half to one full turn.
4. Install Rotational Stop (90) and secure with Cap Screw (91). The nose should be free to rotate approximately 45 degrees from the vertical in either direction (90 degrees included).

# TROUBLESHOOTING

Always check out the simplest possible cause of a malfunction first. For example, an air hose not connected. Then proceed logically, eliminating each possible cause until the cause is located. Where possible, substitute known good parts for suspected bad parts. Use TROUBLESHOOTING CHART as an aid in locating and correcting malfunction.

## NOTE:

Piston Drift is when the air piston is in the down position, but the hydraulic pull piston is not in the full forward position. This causes an out of sequence condition.

- 1 Tool fails to operate when trigger is depressed.**
  - a) Air line not connected
  - b) Throttle Valve O-rings (66), worn or damaged.
  - c) Throttle valve Cable Assembly (2) is broken.
- 2 Tool does not complete fastener installation and break pintail.**
  - a) Air pressure too low
  - b) Air Piston Quad-Ring (52) worn or damaged.
  - c) Reservoir empty or low, refer to Fill and Bleed section.
  - d) Air in hydraulic system, refer to Fill and Bleed section.
  - e) Reservoir Springs (71) worn or damaged
  - f) Check for piston drift
- 3 Pintail stripped and/or swaged collar not ejected.**
  - a) Check for broken or worn jaws in nose assembly, refer to nose assembly data sheet.
  - b) Check for loose Retaining Nut (7)
  - c) Check for piston drift.
- 4 Tool has piston drift.**
  - a) Loose collet crashing into the front of the anvil, this causes the relief valve to open allowing the piston to drift. Tighten the collet and refer to Fill and Bleed section.
  - b) Worn or damaged Return Pressure Relief Valve in tool, inspect Seat Assembly (80), O-ring (27), Back-up Rings (28), Steel Ball (81) and Valve Spring (84). Replace if necessary.
  - c) Worn or damaged Piston Assembly (33); Inspect O-ring (35), O-ring (38) and Back-up Rings (36). Replace if necessary.
- 5 Hydraulic fluid exhausts with air or leaks at base of handle.**
  - a) Worn or damaged Gland Assembly (41); Inspect Polyseal (43), O-rings (46 & 49) and Quad-Ring (48). Replace if necessary.

- 6. Hydraulic fluid leaks at rear of Pull Piston (18)**
  - a) Worn or damaged Rear Gland (19), inspect Polyseal (24) and O-ring (20). Replace if necessary.
- 7. Hydraulic fluid leaks at front of Pull Piston (18).**
  - a) Worn or damaged Front Gland (12); Inspect Polyseal (6), O-ring (14) and Back-up Ring (13). Replace if necessary.
- 8. Pull Piston (18) will not return.**
  - a) Throttle Valve (67) stuck; Lubricate O-rings (66).
  - b) Throttle Arm (68), Cable Assembly (2) or Trigger (5) binding.
- 9. Air leaks at air Cylinder Head (60).**
  - a) Worn or damaged O-ring (53). Replace if necessary.

# ACCESSORIES

## 244 Tool

<b>Fill and Bleed Bottle (Fig.8)</b>	-	<b>120337</b>
<b>Seat Removal Tool</b>	-	<b>126136</b>
<b>Fill Tool Assy for reservoir (Fig.8)</b>	-	<b>112465</b>
<b>Stall Nut (Fig.8)</b>	-	<b>124090</b>
<b>Retaining Nut (for "Jiffy" style noses)</b>	-	<b>125412</b>
<b>Piston Assembly Tool Kit</b>	-	<b>123110-11</b>
<i>Includes:</i>		
Piston Assembly Tool (Fig. 2)	-	123111-2
Spacer (Fig. 2)	-	123112-2
<b>Service Tool Kit</b>	-	<b>120352-244</b>
<i>Includes:</i>		
Fill and Bleed Bottle (Fig.8)	-	120337
Fill Tool for reservoir (Fig.8)	-	112465
Stall Nut (Fig.8)	-	124090

## 244OS Tool

<b>Fill and Bleed Bottle (Fig.8)</b>	-	<b>120337</b>
<b>Seat Removal Tool</b>	-	<b>126136</b>
<b>Fill Tool Assy for reservoir (Fig.8)</b>	-	<b>112465-1</b>
<b>Main Piston Assembly Tool Kit</b>	-	<b>123110-10</b>
<i>Includes:</i>		
Piston Assembly Tool (Fig. 2)	-	123111-8
Spacer (Fig. 2)	-	123112-8
<b>Service Tool Kit</b>	-	<b>120352-244OS</b>
<i>Includes:</i>		
Fill and Bleed Bottle (Fig.8)	-	120337
Fill Tool Assy (Fig.8)	-	112465

# LIMITED WARRANTIES

**Tooling Warranty:** Huck warrants that tooling and other items (excluding fasteners, and hereinafter referred as "other items") manufactured by Huck shall be free from defects in workmanship and materials for a period of ninety (90) days from the date of original purchase.

**Warranty on "non standard or custom manufactured products":** With regard to non-standard products or custom manufactured products to customer's specifications, Huck warrants for a period of ninety (90) days from the date of purchase that such products shall meet Buyer's specifications, be free of defects in workmanship and materials. Such warranty shall not be effective with respect to non-standard or custom products manufactured using buyer-supplied molds, material, tooling and fixtures that are not in good condition or repair and suitable for their intended purpose.

**THERE ARE NO WARRANTIES WHICH EXTEND BEYOND THE DESCRIPTION ON THE FACE HEREOF. HUCK MAKES NO OTHER WARRANTIES AND EXPRESSLY DISCLAIMS ANY OTHER WARRANTIES, INCLUDING IMPLIED WARRANTIES AS TO MERCHANTABILITY OR AS TO THE FITNESS OF THE TOOLING, OTHER ITEMS, NONSTANDARD OR CUSTOM MANUFACTURED PRODUCTS FOR ANY PARTICULAR PURPOSE AND HUCK SHALL NOT BE LIABLE FOR ANY LOSS OR DAMAGE, DIRECTLY OR INDIRECTLY, ARISING FROM THE USE OF SUCH TOOLING, OTHER ITEMS, NONSTANDARD OR CUSTOM MANUFACTURED PRODUCTS OR BREACH OF WARRANTY OR FOR ANY CLAIM FOR INCIDENTAL OR CONSEQUENTIAL DAMAGES.**

Huck's sole liability and Buyer's exclusive remedy for any breach of warranty shall be limited, at Huck's option, to replacement or repair, at FOB Huck's plant, of Huck manufactured tooling, other items, nonstandard or custom products found to be defective in specifications, workmanship and materials not otherwise the direct or indirect cause of Buyer supplied molds, material, tooling or fixtures. Buyer shall give Huck written notice of claims for defects within the ninety (90) day warranty period for tooling, other items, nonstandard or custom products described above and Huck shall inspect products for which such claim is made.

**Tooling, Part(s) and Other Items not manufactured by Huck.**

**HUCK MAKES NO WARRANTY WITH RESPECT TO THE TOOLING, PART(S) OR OTHER ITEMS MANUFACTURED BY THIRD PARTIES. HUCK EXPRESSLY DISCLAIMS ANY WARRANTY EXPRESSED OR IMPLIED, AS TO THE CONDITION,**

**DESIGN, OPERATION, MERCHANTABILITY OR FITNESS FOR USE OF ANY TOOL, PART(S), OR OTHER ITEMS THEREOF NOT MANUFACTURED BY HUCK. HUCK SHALL NOT BE LIABLE FOR ANY LOSS OR DAMAGE, DIRECTLY OR INDIRECTLY, ARISING FROM THE USE OF SUCH TOOLING, PART(S) OR OTHER ITEMS OR BREACH OF WARRANTY OR FOR ANY CLAIM FOR INCIDENTAL OR CONSEQUENTIAL DAMAGES.**

The only warranties made with respect to such tool, part(s) or other items thereof are those made by the manufacturer thereof and Huck agrees to cooperate with Buyer in enforcing such warranties when such action is necessary.

Huck shall not be liable for any loss or damage resulting from delays or nonfulfillment of orders owing to strikes, fires, accidents, transportation companies or for any reason or reasons beyond the control of the Huck or its suppliers.

## ***Huck Installation Equipment***

Huck International, Inc. reserves the right to make changes in specifications and design and to discontinue models without notice.

Huck Installation Equipment should be serviced by trained service technicians only.

Always give the Serial Number of the equipment when corresponding or ordering service parts.

Complete repair facilities are maintained by Huck International, Inc. Please contact one of the offices listed below.

### Eastern

One Corporate Drive Kingston, New York 12401-0250  
Telephone (845) 331-7300 FAX (845) 334-7333

### Canada

6150 Kennedy Road Unit 10, Mississauga, Ontario, L5T2J4, Canada.  
Telephone (905) 564-4825 FAX (905) 564-1963

### Outside USA and Canada

Contact your nearest Huck International Office, see back cover.

In addition to the above repair facilities, there are Authorized Tool Service Centers (ATSC's) located throughout the United States. These service centers offer repair services, spare parts, Service Parts Kits, Service Tools Kits and Nose Assemblies. Please contact your Huck Representative or the nearest Huck office listed on the back cover for the ATSC in your area.



For the Long Haul™

## A Global Organization

Alcoa Fastening Systems (AFS) maintains company offices throughout the United States and Canada, with subsidiary offices in many other countries. Authorized AFS distributors are also located in many of the world's

industrial and Aerospace centers, where they provide a ready source of AFS fasteners, installation tools, tool parts, and application assistance.

## Alcoa Fastening Systems world-wide locations:

### Americas

#### **Alcoa Fastening Systems**

##### Aerospace Products

##### Tucson Operations

3724 East Columbia  
Tucson, AZ 85714  
800-234-4825  
520-747-9898  
FAX: 520-748-2142

#### **Alcoa Fastening Systems**

##### Aerospace Products

##### Carson Operations

PO Box 5268  
900 Watson Center Rd.  
Carson, CA 90749  
800-421-1459  
310-830-8200  
FAX: 310-830-1436

#### **Alcoa Fastening Systems**

##### Commercial Products

##### Waco Operations

PO Box 8117  
8001 Imperial Drive  
Waco, TX 76714-8117  
800-388-4825  
254-776-2000  
FAX: 254-751-5259

#### **Alcoa Fastening Systems**

##### Commercial Products

##### Kingston Operations

1 Corporate Drive  
Kingston, NY 12401  
800-431-3091  
845-331-7300  
FAX: 845-334-7333  
www.hucktools.com

#### **Alcoa Fastening Systems**

##### Commercial Products

##### Canada Operations

6150 Kennedy Road, Unit 10  
Mississauga, Ontario L5T2J4  
Canada  
905-564-4825  
FAX: 905-564-1963

#### **Alcoa Fastening Systems**

##### Commercial Products

##### Latin America Operations

Avenida Parque Lira. 79-402  
Tacubaya Mexico, D.F.  
C.P. 11850  
FAX: 525-515-1776  
TELEX: 1173530 LUKSME

### Far East

#### **Alcoa Fastening Systems**

##### Commercial Products

##### Australia Operations

14 Viewtech Place  
Rowville, Victoria  
Australia 3178  
03-764-5500  
Toll Free: 008-335-030  
FAX: 03-764-5510

### Europe

#### **Alcoa Fastening Systems**

##### Commercial Products

##### United Kingdom Operations

Unit C, Stafford Park 7  
Telford, Shropshire  
England TF3 3BQ  
01952-290011  
FAX: 0952-290459

#### **Alcoa Fastening Systems**

##### Aerospace Products

##### France Operations

Clos D'Asseville  
BP4  
95450 Us Par Vigny  
France  
33-1-30-27-9500  
FAX: 33-1-34-66-0600

For The Long Haul, The Future of Fastening Technology, The Future of Assembly Technology, The Future of Tooling Technology, and Tools of Productivity are service marks of Huck International. Huck provides technical assistance regarding the use and application of Huck fasteners and tooling.

NOTICE: The information contained in this publication is only for general guidance with regard to properties of the products shown

and/or the means for selecting such products, and is not intended to create any warranty, express, implied, or statutory; all warranties are contained only in Huck's written quotations, acknowledgements, and/or purchase orders. It is recommended that the user secure specific, up-to-date data and information regarding each application and/or use of such products.

HWB898 1003-5M



# Alcoa Fastening Systems



One Great Connection<sup>SM</sup>