

ORIGINAL INSTRUCTIONS

G704B

Lightweight CherryMAX® Power Tool
N S N 5130-01-393-1584



MANUAL



CHERRY®
AEROSPACE

1224 East Warner Ave,
Santa Ana, Ca 92705
Tel: 1-714-545-5511
Fax: 1-714-850-6093
www.cherryaerospace.com

THE G704B TOOL

TABLE OF CONTENTS

Description	3
Specifications for G704B	3
Safety Warnings	4
How To Use The G704B	5
Maintenance And Repair	5
Fill And Bleed Instructions	6
Trouble Shooting	6
Overhaul	7
Air Valve	7
Head Sub-Assembly	7
Handle Sub-Assembly	8
Pulling Heads	8
Cross Section Drawing Of G704B	9
Parts List For G704B Riveter	10
Exploded View Of G704B	11
Declaration Of Conformity	Back Cover

DESCRIPTION

The Cherry G704B is a pneumatic-hydraulic tool designed specifically for the most efficient installation of CherryMAX® 3/4" (19.05 mm) rivets. Its durable, all metal housing makes this extremely robust tool ideal for use in rugged shop environments. This tool utilizes straight, offset and right-angle pulling heads, all of which can install -4, -5, and -6 diameter CherryMAX® bulb type rivets in all head styles, materials and grip lengths. Extensions are available for extending the pulling heads to reach limited access areas. See the section on pulling heads for the correct pulling head part number.

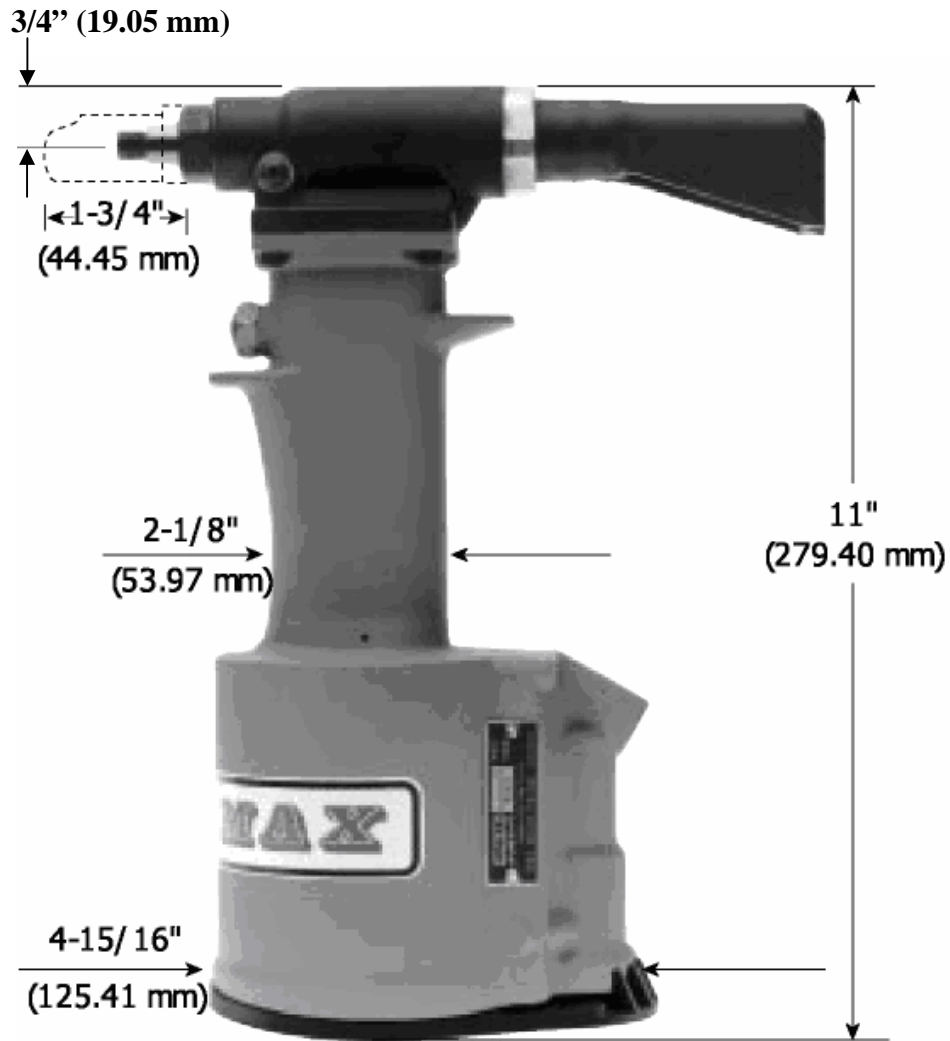

SPECIFICATIONS FOR G704B

Cherry Aerospace' (CHERRY) policy is one of continuous development. Specifications shown in this document may be subject to change which may be introduced after publication. For the latest information always consult CHERRY.

AIR PRESSURE	90 PSI (6.2 bar) Min./ 110 PSI (7.6 bar) Max.
STROKE	.510 Inch (12.954 mm)
PULLING FORCE	3100 Pounds (13.79 kn) @ 90 PSI (6.2 bar)
CYCLE TIME	Approximately One Second
WEIGHT	4 1/4 Pounds (1.93 kg)
NOISE LEVEL	71 dB (A)
VIBRATION	2.5 m/s ²
AIR CONSUMPTION	3.9 CFM (110.5 liters/M) at 20 Cycles per Minute

SAFETY WARNINGS

- Operating this tool with a damaged or missing stem deflector, or using the deflector as a handle, may result in severe personal injury. The pin deflector should be rotated until the aperture is facing away from the operator and other persons working in the vicinity.
- Approved eye protection should be worn when operating, repairing, or overhauling this tool.
- Do not use beyond the design intent.
- Do not use substitute components for repair.
- Any modification to the tool, pulling heads, accessories or any component supplied by Cherry®, or their representatives, shall be the customer's entire responsibility.
Cherry® will be pleased to advise on any proposed modification.
- The tool must be maintained in a safe working condition at all times and examined at regular intervals for damage.
- Before disassembling the tool for repair, refer to the maintenance instructions. All repairs shall be undertaken only by personnel trained in Cherry® installation tools.
Contact Cherry® with your training requirement.
- Always disconnect the air line from the tool inlet before attempting to service, adjust, fit or remove any accessory.
- Do not operate the tool when it is directed at any person.
- Ensure that the vent holes do not become blocked or covered and that air line hoses are always in good condition.
- Excessive contact with the hydraulic fluid should be avoided to minimize the possibility of rashes. Care should be taken to wash thoroughly.
- Operating air pressure should not exceed 110 psi (7.6 bar).
- Do not operate the tool without the pulling head in place.
- Do not operate the tool unless the handle base (26) is fully secured by the retaining ring (27).
- All retaining rings, screwed end caps, air fittings, trigger valves and pulling heads should be attached securely and examined at the end of each working shift.
- Do not pull rivet in the air.
- The precautions to be used when using this tool must be explained by the customer to all operators. **Any questions regarding the correct operation of the tool and operator safety should be directed to Cherry®.**
- Do not pound on the rear of the tool head to force rivets into holes as this will damage the tool.
- Do not depress the trigger while disconnecting the air bleeder and replacing the cap screw when bleeding the tool.

HOW TO USE THE G704B

After selecting the proper pulling head and attaching it securely to the G704B, connect the air line to the tool. Insert the rivet stem into the pulling head until the head of the rivet is in contact with the pulling head sleeve. This will ensure full engagement between the jaws and the rivet stem and will prevent slippage.

Once the rivet stem is inserted in the H701B-456 pulling head, the rivet must be installed. The "stem stop" in the pulling head will prevent the mandrel from moving back out the front of the head.

Insert the rivet into the application and pull the trigger to activate the tool. Upon the release of the trigger, the stem will eject to the rear of the tool (when using the H701B-456 straight pulling head). When using the H781-456 offset pulling head, the stem will eject through the offset pulling head to the rear. When using the H753A-456 right angle pulling head, the stem will eject out the front.

MAINTENANCE AND REPAIR

The G704B has been manufactured to give maximum service with minimum care. In order that this may be accomplished, the following recommendations should be followed:

1. The hydraulic system should be full of fluid and free from air at all times.
2. Keep excessive moisture and dirt out of air supply to prevent wear of air valve, air cylinder and air piston.
3. Tool should be routinely inspected for oil leaks.

Use automatic transmission fluid Type "A" (no substitutes). CHERRY recommends using Dexron® III ATF.

DEXRON III OIL SAFETY DATA

FIRST AID

Skin: Wash thoroughly with soap and water as soon as possible. Casual contact requires no immediate attention. If irritation develops, consult a physician.

Ingestion: Seek medical attention immediately. DO NOT INDUCE VOMITING.

Eyes: Flush with copious amounts of water. If irritation develops, consult a physician.

Inhalation: No significant adverse health effects are expected to occur on short term exposure. Remove from contaminated area. Apply artificial respiration if needed. If unconscious, consult physician.

FIRE

Suitable extinguishing media: CO₂, dry powder, foam or water fog. DO NOT use water jets.

ENVIRONMENT

Waste Disposal: In accordance with local, state and federal regulations.

Spillage: Prevent entry into drains, sewers and water courses. Soak up with diatomaceous earth or other inert material. Store in appropriate container for disposal.

HANDLING

Eye protection required. Protective gloves recommended. Chemically resistant boots and apron recommended. Use in well ventilated area.

COMBUSTIBILITY

Slightly combustible when heated above flash point. Will release flammable vapor which can burn in open or be explosive in confined spaces if exposed to source of ignition.

STORAGE

PROPERTIES

<i>Specific gravity</i>	0.863
<i>Weight per gallon</i>	7.18 lbs.
<i>Open flash point</i>	>200°C (392°F)

FILL AND BLEED INSTRUCTIONS

To replace a small amount of fluid in the tool, remove cap screw (14), attach the Cherry air bleeder (700A77), connect the tool to the air line and cycle several times. This will ensure the removal of any air from the hydraulic system and its replacement with fluid.

Should it become necessary to completely refill the tool (such as would be required after the tool has been dismantled and reassembled), take the following steps:

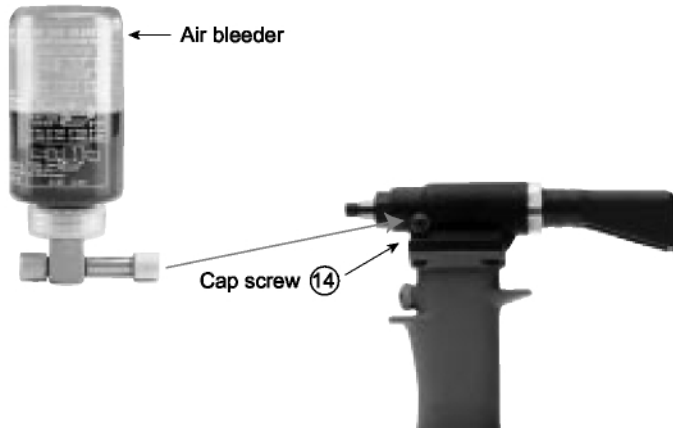

1. Remove head assembly (1) from handle (30) by unscrewing cap screws (49).
2. Fill handle assembly (30) with the recommended oil to within 1/8" (3.175mm) of the top of the handle casting.
3. Place head assembly (1) on handle (30), being sure gasket (48), and O-ring (47), are properly in place. Tighten cap screws (49) uniformly to prevent leakage around gasket.
4. Attach the Cherry air bleeder (700A77). Connect the tool to the air line and cycle a number of times. This will ensure the removal of any air from its hydraulic system and its replacement with fluid.

DO NOT depress trigger while disconnecting the air bleeder and replacing the cap screw (14).

TROUBLESHOOTING

1. Check the airline for correct pressure at the tool. It must be 90 to 110 psi (6.2 to 7.6 bar).
2. Check the tool for lack of fluid (see Fill and Bleed instructions).
3. Check for oil leakage:
 - Fluid leaking around the cap screw (14) in the head indicates that the screw is loose or the Stat-O-Seal (13) needs replacing.
 - If fluid should leak through the by-pass hole at the base of the handle (30) the O-rings (32) are worn or damaged.
 - Fluid leaking from the front of the head (1) indicates that O-rings (2) are worn or damaged.
4. Check for excessive air leakage from the air valve:
 - If spring (38) is broken or dislodged, air will bleed directly through the bottom of the air valve and the head piston retreats to its full stroke without returning. See air valve instructions on page 5.
 - If O-ring (43) on plug (44) is worn or damaged, replace.
 - If O-rings (39) on spool valve (40) are worn or damaged, replace.
5. Check movement of the head piston (4). If it does not move freely or is slow in operation:
 - O-rings (2), (5) and (7) may be damaged and require replacement.
 - Head piston (4) may be mechanically locked due to damaged parts.
 - The O-ring (34) on power piston (35) may be damaged; replace.
 - Muffler (45) or air filter (41) inside valve spool (40) may be plugged with dirt. Clean them thoroughly with normal solvent and back-blow with compressed air.
 - Hole in metering screw (42) in valve spool (40) may be blocked or damaged. Hole diameter should be .028" (.7112 mm). Clear and size or replace valve spool assembly (52).
5. Rivet stem sticks in the pulling head:
 - Pulling head components need maintenance. Disassemble the pulling head, clean and replace worn parts. Reassemble as per the instructions given in pulling head tool sheets.
 - Spent rivet stems are wedged side by side in the head piston (4). Disassemble the pulling head, remove stems and reassemble by the instructions given in pulling head tool sheets.

OVERHAUL

The disassembly and reassembly procedures can be accomplished by following the instructions below and the drawings on pages 8 & 9. **Use extreme care during disassembly and reassembly not to mar, nick or burr any smooth surface that comes in contact with O-rings.** Before installing O-rings, be sure to apply an O-ring lubricant. It is recommended that special assembly tools, which can be ordered under part number **G701/G704KT**, be used to overhaul this tool Service kit, **G704KS**, which contains a complete set of O-rings, back-up rings, screws, washers and gaskets should be ordered.

Not shown, but included: 701A67 Seal Guide, 702B62 Power Cylinder Tool, 703A53 Seal Guide, 702A64 Seal Guide, and 744-103 Seal Guide.

THE G701/G704KT TOOL KIT



AIR VALVE

- Disconnect tool from air supply and remove retaining ring (46) and muffler (45). Insert a valve plug extractor (P1178) into end of valve plug (44) and pull it out. Using the same procedures, pull out valve spool sub-assembly (52).
- Use needle nose pliers to grasp the end of the spring (38), turn clockwise and pull out to dislodge from groove in handle.
- With spring removed, valve sleeve (37) can be pulled out using the valve sleeve removal tool (837B700).

To reassemble, reverse the above procedures, being certain that all O-rings are properly lubricated. To avoid damaging the O-rings (36), carefully install sleeve (37) with your finger. Gently push and wiggle sleeve to allow O-rings to slip past inner ports. Spring (38) is best installed using a valve spring installation tool (836B700) to push the **large** diameter coil into the groove. This requires care as the tool will not operate if the spring is not anchored firmly.

HEAD SUB-ASSEMBLY

- Disconnect tool from air supply and remove the complete pulling head from the tool before attempting to disassemble the head assembly.
- Remove the four socket head cap screws (49). Lift head assembly from the handle (30). Remove O-ring (47) and gasket (48). Empty the oil into a container by pouring from the handle. Dispose of the oil according to environmental regulations.
- Remove end cap (9). Push against threaded end of head piston (4) and slide it out of head cylinder (1). Be careful not to damage threads or cause burrs on polished head piston rod surface.
- O-rings (2) and back-up rings (3) can now be removed using a bent hook. O-ring (8) can be removed in the same manner.

Upon re-assembly, be sure to install O-rings and back-up rings carefully to avoid cutting them. Always lubricate all O-rings. Just prior to placing the head sub-assembly on to the handle, see Fill and Bleed Instructions. Also make sure to place O-ring (47) and the gasket (48) on the top of the handle, and that they are properly oriented.

HANDLE SUB-ASSEMBLY

- Disconnect tool from air supply and remove parts (23) through (27).
- Place piston rod wrench (700A61) down into the top of the handle (30), into the hex socket in the head of the power piston rod (35). While holding this wrench, remove the locknut (22) using the 7/16" socket.
- Still holding the piston rod wrench, remove the air piston (21) using the packing plug wrench (700B65) by turning counterclockwise. When air piston is completely freed from the piston rod, tap or push on the piston rod wrench to eject the piston from bottom of handle.
- Slide power piston rod (35) back up to the end of its travel. Using the packing plug wrench (700B65), remove packing plug (18). It may be necessary to hold the handle upside down in a vise while removing the packing plug. The O-rings (16) and backup rings (15) are best removed and replaced by using a thin bent hook.
- Power cylinder (31) can be tapped out by lowering power cylinder tool (700A62) down into the top of the handle on to top of cylinder.
- To reassemble the handle, reverse the above procedure, being certain that all the O-rings are properly lubricated before installation. Attach the seal guide (700A60) to the piston rod (35) and with a mallet, tap the piston rod through the packing plug (18). When reassembling a replacement air piston, items (19) through (22), follow the instructions given below:
- Clamp piston rod wrench (700A61) in a vise with the hex shaft pointed up.
- Turn the handle upside down and place the hex end of the power piston rod (35) onto the wrench. Push handle casting down until it stops.
- Assemble seal (20) and back-up rings (19) to air piston (21).
- Place the air piston (21) into handle bore. Thread the locknut (22) onto the power piston rod (35) and tighten between 50 in.-lb (5.65 N-m) and 59 in.-lb (6.67 N-m).

G704B PULLING HEADS

Pulling Heads are not furnished with riveter and must be ordered separately.

Pulling Head	Type	Adapter	Rivet	Rivet Diameters	Maximum Grip ¹
H701B-456	Straight	-	CherryMAX Bulb	1/8, 5/32, 3/16 ^{2,3}	All
			CherryMAX "AB"	1/8, 5/32, 3/16 ³	-4 ¹
			MBC L/C	1/8, 5/32, 3/16	-4 ¹
H753A-456	Right Angle	-	CherryMAX Bulb	1/8, 5/32, 3/16 ^{2,3}	All
			CherryMAX "AB"	1/8, 5/32, 3/16 ³	-4 ¹
H781-456	Offset	-	CherryMAX Bulb	1/8, 5/32, 3/16 ^{2,3}	All
			CherryMAX "AB"	1/8, 5/32, 3/16 ³	-4 ¹
H9015-Series	Straight	704A9	MS ⁴	3/32, 1/8, 5/32, 3/16	All
H955-Series	Straight	-	CherryLock "A"	3/32, 1/8, 5/32, 3/16 ³	-4 ¹
H782	Straight	-	CherryMAX Bulb	1/8, 5/32, 3/16 ^{2,3}	All
			CherryMAX "AB"	1/8, 5/32, 3/16 ³	-4 ¹
			MBC L/C	1/8, 5/32, 3/16	-4 ¹

1. On the first stroke. 2. Nominal and oversize. 3. No 3/16 aluminum, alloy steel and monel only. 4. Serrated stems only.

5. See H782 tool sheet for complete list of fastener compatibility.

FOR MOUNTING AND OPERATING INSTRUCTIONS SEE PULLING HEAD TOOL SHEETS.

CROSS SECTION OF G704B

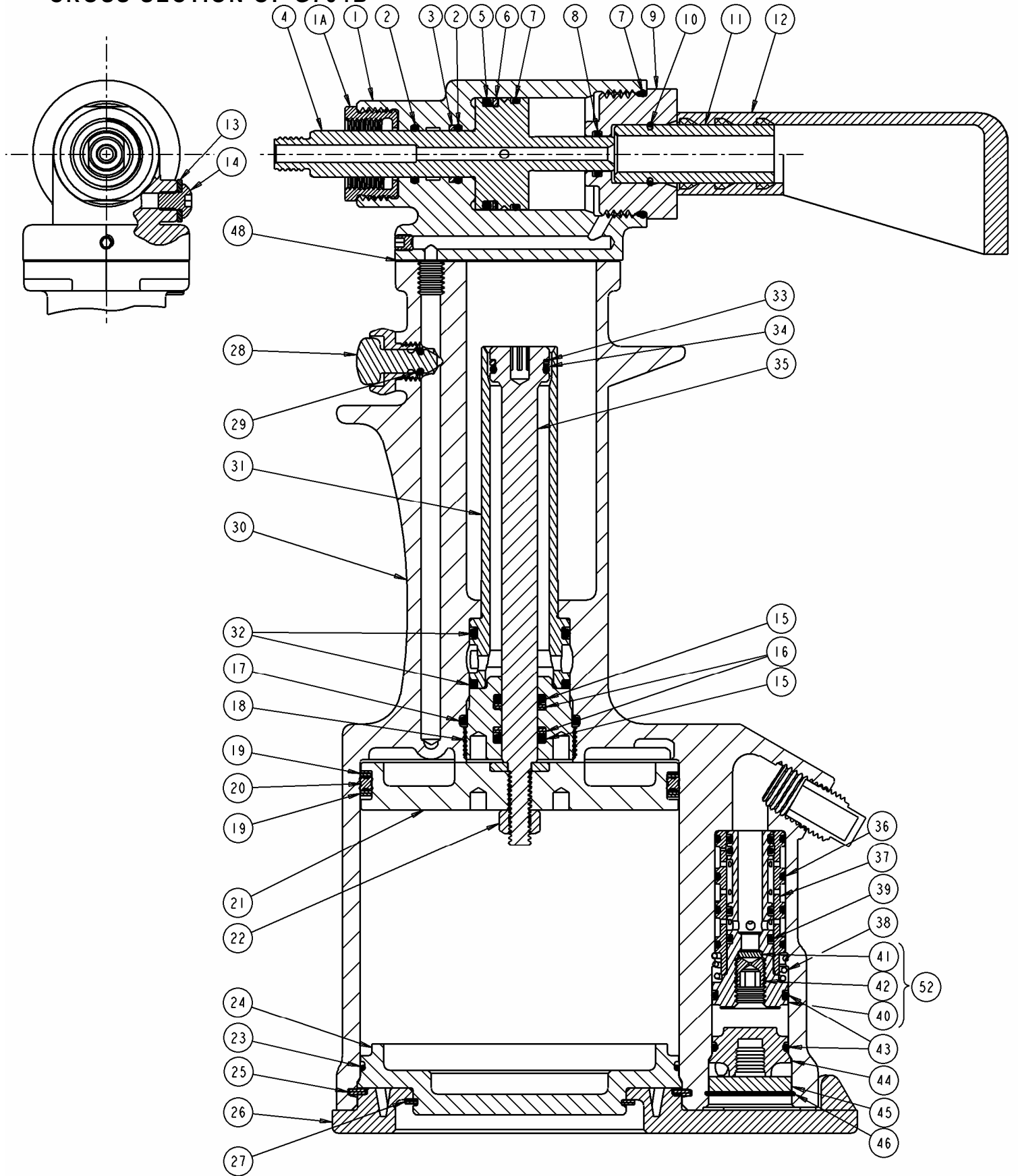

PART LIST FOR THE G704B (704-087) CHERRYMAX RIVETER ASSEMBLY

ITEM NO.	DESCRIPTION	QTY.		
704B35 SUB-ASSEMBLY, HEAD				
704C19 SUB-ASSEMBLY, HEAD CYLINDER				
	1	704C18 CYLINDER, HEAD	1	
	1A	704B2-2 FITTING, NOSE	1	
2	P-701	O-RING (.629, .489, .070)	2	
3	P-998	RING, BACK-UP (.609, .503, .053)	1	
4	704C3	PISTON, HEAD	1	
5	P-931	O-RING (1.193, .987, .103)	1	
6	P-1000	RING, BACK-UP (1.176, 1.000, .088)	1	
7	P-870	O-RING (1.191, 1.051, .070)	2	
8	P-112	O-RING (.504, .364, .070)	1	
9	704B4	CAP, HEAD CYLINDER	1	
10	P-880	RING, RETAINING (NON-STANDARD)	1	
11	703A13	FITTING, DEFLECTOR	1	
12	530A16	DEFLECTOR, PIN	1	
13	P-572	STAT-O-SEAL (.443, .180, .132)	1	
14	P-573	SCREW, BUTTON HD. SOC. 10-32 x 1/4	1	
704-086 SUB-ASSEMBLY, HANDLE				
15	P-838**	O-RING, DISOGRIN (.568, .362, .103)	2	
16	P-115	RING, BACK-UP (.551, .375, .088)	2	
17	P-727	O-RING (1.318, 1.112, .103)	1	
18	700B93	PLUG, PACKING	1	
19	P-731	RING, BACK-UP (3.387, 3.109, .139)	2	
20	P-730	RING, QUAD (3.387, 3.109, .139)	1	
21	700B6	PISTON, AIR	1	
22	P-737	NUT, CONELOK, 1/4-20	1	
23	P-725	O-RING (3.129, 2.989, .070)	1	
24	700B4	BASE, HANDLE	1	
25	P-735	RING, RETAINING (INT. Ø3.500)	1	
26	700D107	COVER, BASE	1	
27	P-736	RING, RETAINING (EXT. Ø2.250)	1	
28	703A33	ASSEMBLY, TRIGGER (INCLUDES P-223)	1	
29	P-223	O-RING (.285, .145, .070)	1	
30	703A11	HANDLE	1	
31	700-247	CYLINDER, POWER	1	
32	P-833**	O-RING, DISOGRIN (1.068, .862, .103)	2	
33	P-739	RING, BACK-UP (.614, .518, .056)	1	
34	P-830**	O-RING, DISOGRIN (.629, .489, .070)	1	
35	700-248	ROD, POWER PISTON	1	
36	P-653	O-RING (.691, .551, .070)	4	
37	700B96	SLEEVE, VALVE	1	
38	700A67	SPRING	1	
39	P-829**	O-RING, DISOGRIN (.504, .364, .070)	4	
52	700A94	SUB-ASSEMBLY, VALVE SPOOL		
	40	700B95 SPOOL, VALVE	1	
	41	700A18 FILTER	1	
	42	700A69 SCREW, METERING	1	
	43	P-834**	O-RING, DISOGRIN (.816, .676, .070)	2
	44	700A16	PLUG, VALVE	1
	45	700A17	MUFFLER	1
	46	P-279	RING, RETAINING (INT. Ø.906)	1
47	P-832**	O-RING, DISOGRIN (.379, .239, .070)	1	
48	700A22	GASKET	1	
49	P-27	SCREW, SOC. HD. CAP, 8-32 x 1/2	4	
50	670A20*	BAG, MANDREL CATCHER	1	
51	P-948*	HOSE, AIR	1	

*Not furnished with riveter. Must be ordered separately if desired.

**No substitutions.

Note: Use Loctite #271 or equivalent when assembling items 1 and 1A.

All dimensions in inches.

EXPLODED VIEW OF G704B

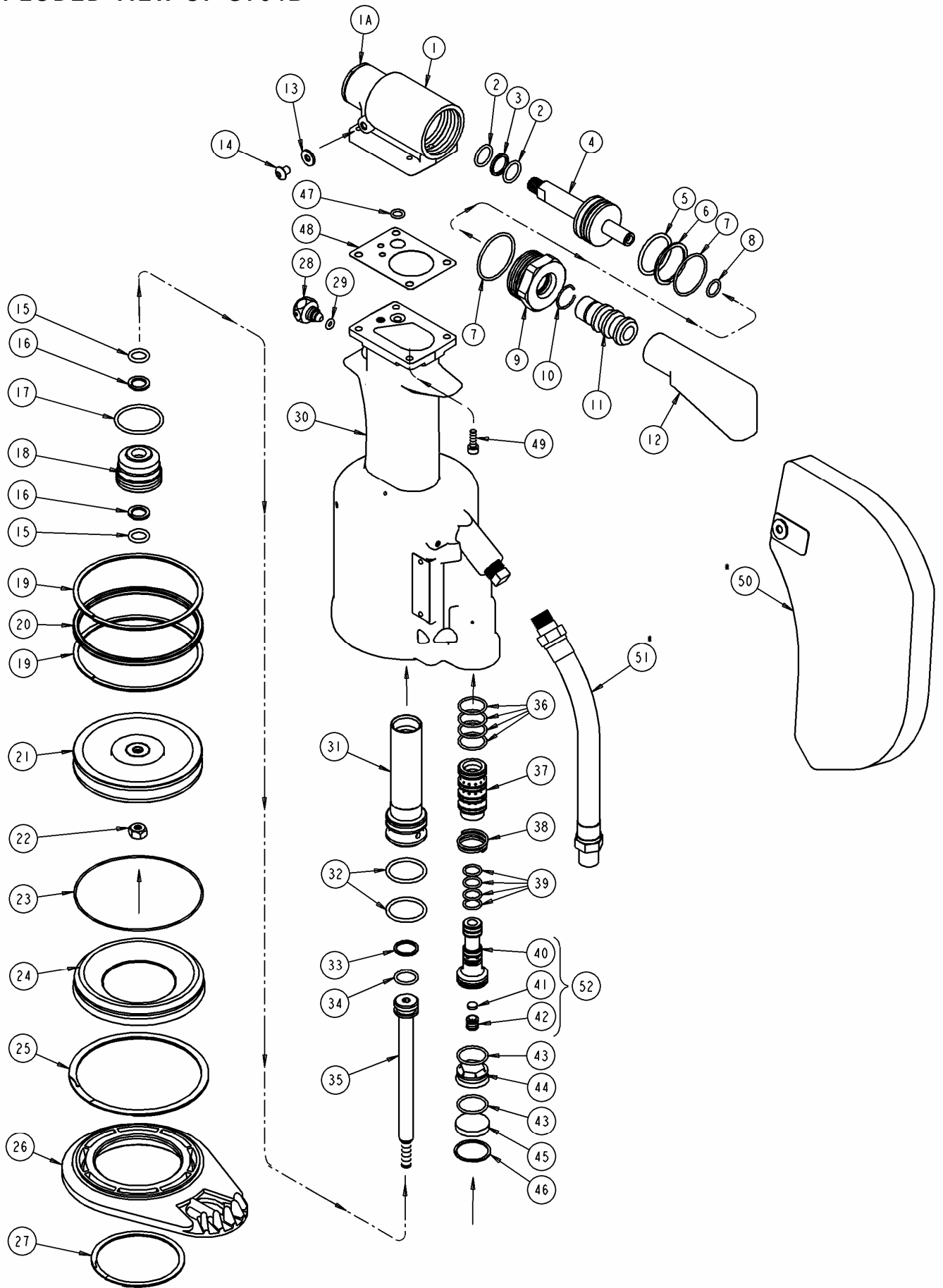

Declaration of Conformity

We, Cherry Aerospace, 1224 E. Warner Ave., Santa Ana, CA 92705

declare under our sole responsibility that the product

type G704B

Serial No.-

to which this declaration relates is in conformity with the following standards

EN292 part 1 and part 2

ISO 8662 Part 1

ISO 3744

following the provisions of the Machine Directive 89/392/EEC
(as amended by Directive 91/368/EEC) and 93/68/EEC

Santa Ana, CA
date of issue

Original Certification and signature on file

WARRANTY

Seller warrants the goods conform to applicable specifications and drawings and will be manufactured and inspected according to generally accepted practices of companies manufacturing industrial or aerospace fasteners. In the event of any breach of the foregoing warranty, Buyer's sole remedy shall be to return defective goods (after receiving authorization from Seller) for replacement or refund of the purchase price, at the Seller's option. Seller agrees to any freight costs in connection with the return of any defective goods, but any costs relating to removal of the defective or nonconforming goods or installation of replacement goods shall be Buyer's responsibility. SELLER'S WARRANTY DOES NOT APPLY WHEN ANY PHYSICAL OR CHEMICAL CHANGE IN THE FORM OF THE PRODUCT IS MADE BY BUYER.

THE FOREGOING EXPRESS WARRANTY AND REMEDY ARE EXCLUSIVE AND ARE IN LIEU OF ALL OTHER WARRANTIES AND REMEDIES; ANY IMPLIED WARRANTY AS TO QUALITY, FITNESS FOR PURPOSE, OR MERCHANTABILITY IS HEREBY SPECIFICALLY DISCLAIMED AND EXCLUDED BY SELLER. THIS WARRANTY IS VOID IF SELLER IS NOT NOTIFIED IN WRITING OF ANY REJECTION OF THE GOODS WITHIN ONE (1) YEAR AFTER INITIAL USE BY BUYER OF ANY POWER RIVETER OR NINETY (90) DAYS AFTER INITIAL USE OF ANY OTHER PRODUCT.

Seller shall not be liable under any circumstances for incidental, special or consequential damages arising in whole or in part from any breach by Seller, AND SUCH INCIDENTAL, SPECIAL, OR CONSEQUENTIAL DAMAGES ARE HEREBY EXPRESSLY EXCLUDED.

For more information please contact our Technical Services Department at Tel. 714-850-6022

LOCTITE® is a registered trademark of Henkel Corporation
DEXRON® is a registered trademark of GM corporation.
PARKER® is a trademark of Parker Hannifin Corporation
LUBRRIPLATE® is a trademark of Fiske Brothers Refining Co.



© 2007 Cherry Aerospace

CHERRY®
AEROSPACE

Supplier's Federal Identification Code: 11815

1224 East Warner Ave,
Santa Ana, Ca 92705
Tel: 1-714-545-5511
Fax: 1-714-850-6093
www.cherryaerospace.com

TM-G704B
Rev.: A
Date: 02/05/07
DCR# 06-0786